

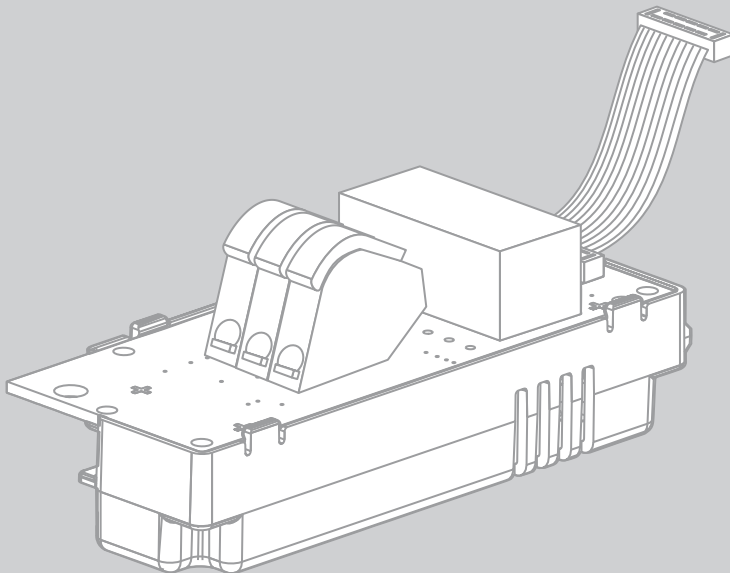

Installation Manual  
**MULTIFUNCTION RELAY**



## Legal Provisions

The information contained in this document is the property of SMA Solar Technology AG. Publishing its content, either partially or in full, requires the written permission of SMA Solar Technology AG. Any internal company copying of the document for the purposes of evaluating the product or its correct implementation is allowed and does not require permission.

### SMA Warranty

You can download the current warranty conditions from the Internet at [www.SMA-Solar.com](http://www.SMA-Solar.com).

### Trademarks

All trademarks are recognized, even if not explicitly identified as such. A lack of identification does not mean that a product or symbol is not trademarked.

The BLUETOOTH® word mark and logos are registered trademarks owned by Bluetooth SIG, Inc. and any use of these marks by SMA Solar Technology AG is under license.

Modbus® is a registered trademark of Schneider Electric and is licensed by the Modbus Organization, Inc.

QR Code is a registered trademark of DENSO WAVE INCORPORATED.

Phillips® and Pozidriv® are registered trademarks of Phillips Screw Company.

Torx® is a registered trademark of Acument Global Technologies, Inc.

### SMA Solar Technology AG

Sonnenallee 1  
34266 Niestetal  
Germany

Tel. +49 561 9522-0

Fax +49 561 9522-100

[www.SMA.de](http://www.SMA.de)

E-mail: [info@SMA.de](mailto:info@SMA.de)

© 2004 to 2014 SMA Solar Technology AG. All rights reserved.

# Table of Contents

<b>1</b>	<b>Information on this Document</b>	<b>5</b>
1.1	Validity	5
1.2	Target Group	5
1.3	Symbols	5
1.4	Typographies	6
1.5	Nomenclature	6
1.6	Display of Parameters	6
<b>2</b>	<b>Safety</b>	<b>7</b>
2.1	Intended Use	7
2.2	Safety Information	8
2.3	Symbol on the Product	8
<b>3</b>	<b>Scope of Delivery</b>	<b>9</b>
<b>4</b>	<b>Electrical Connection</b>	<b>10</b>
4.1	Safety during Electrical Connection	10
4.2	Electrical Connection Procedure	10
4.3	Overview of the Connection Area	11
4.4	Installing the Multifunction Relay	11
4.4.1	Mounting Position and Cable Route	11
4.4.2	Installing the Multifunction Relay in the Sunny Boy Smart Energy	13
4.4.3	Installing the Multifunction Relay in the Sunny Boy / Windy Boy or Sunny Tripower	15
4.5	Selecting the Operating Mode	17
4.6	Connecting the Multifunction Relay	18
4.6.1	Connection Options for the Multifunction Relay	18
4.6.2	Connecting to the Multifunction Relay	22
<b>5</b>	<b>Changing the Operating Mode of the Multifunction Relay</b>	<b>24</b>
<b>6</b>	<b>Technical Data</b>	<b>25</b>
<b>7</b>	<b>Contact</b>	<b>26</b>
<b>8</b>	<b>EC Declaration of Conformity</b>	<b>29</b>



# 1 Information on this Document

## 1.1 Validity





This document is valid for device type "MFR01-10".

## 1.2 Target Group

The tasks described in this document must be performed by qualified persons only. Qualified persons must have the following skills:

- Knowledge of how an inverter works and is operated
- Training in how to deal with the dangers and risks associated with installing and using electrical devices and installations
- Training in the installation and commissioning of electrical devices and installations
- Knowledge of the applicable standards and directives
- Knowledge of and compliance with this document, including all safety precautions

## 1.3 Symbols

Symbol	Explanation
 <b>DANGER</b>	Indicates a hazardous situation which, if not avoided, will result in death or serious injury
 <b>WARNING</b>	Indicates a hazardous situation which, if not avoided, can result in death or serious injury
 <b>CAUTION</b>	Indicates a hazardous situation which, if not avoided, can result in minor or moderate injury
<b>NOTICE</b>	Indicates a situation which, if not avoided, can result in property damage
 <b>QUALIFIED PERSON</b>	Indicates that the following section contains tasks that must only be performed by qualified persons
	Information that is important for a specific topic or goal, but is not safety-relevant
<input type="checkbox"/>	Indicates a requirement for meeting a specific goal
<input checked="" type="checkbox"/>	Desired result
<b>x</b>	A problem that might occur

## 1.4 Typographies

Typography	Use	Example
Bold	<ul style="list-style-type: none"> <li>Parameters</li> <li>Elements to be selected</li> <li>Elements to be entered</li> </ul>	<ul style="list-style-type: none"> <li>Select the parameter <b>Operating mode of multifunction relay</b> or <b>Mlt.OpMode</b> and set the desired operating mode.</li> </ul>

## 1.5 Nomenclature

Complete designation	Designation in this document
Multifunction relay	Multifunction relay, product
Sunny Boy, Windy Boy, Sunny Tripower, Sunny Boy Smart Energy	Inverter
PV system, small wind turbine system	System

## 1.6 Display of Parameters

Depending on the type of communication (e.g. RS485, BLUETOOTH or Speedwire/Webconnect), the parameters are displayed differently in the communication products. This document uses both methods of displaying parameters.

### Example: Display of the parameter for setting the operating mode of the multifunction relay

- For communication via RS485: parameter **Mlt.OpMode**
- For communication via BLUETOOTH or Speedwire/Webconnect: parameter **Operating mode of multifunction relay**

## 2 Safety

### 2.1 Intended Use

The multifunction relay is a multifunctional interface that can be configured for the operating mode used by a particular system (see Section 4.5 "Selecting the Operating Mode", page 17).

The multifunction relay can be retrofitted or installed in the inverter at the factory if specified in the order.

The multifunction relay is suitable for use in the following SMA inverters:

- SB 3000TL-21, SB 3600TL-21, SB 4000TL-21, SB 5000TL-21
- SB 3600SE-10, SB 5000SE-10
- WB 3000TL-21, WB 3600TL-21, WB 4000TL-21, WB 5000TL-21
- SB 2500TLST-21, SB 3000TLST-21
- STP 8000TL-10, STP 10000TL-10, STP 12000TL-10, STP 15000TL-10, STP 17000TL-10
- STP 15000TLHE-10, STP 20000TLHE-10, STP 15000TLEE-10, STP 20000TLEE-10

Use this product only in accordance with the information provided in the enclosed documentation and with the locally applicable standards and directives. Any other application may cause personal injury or property damage.

For safety reasons, it is not permitted to modify the product or install components that are not explicitly recommended or distributed by SMA Solar Technology AG for the product. Unauthorized changes and modifications will void all warranty claims and the operating permission.

Any use of the product other than described in the Intended Use section does not qualify as appropriate.

The enclosed documentation is an integral part of this product. Keep the documentation in a convenient place for future reference and observe all instructions contained therein.

## 2.2 Safety Information

This section contains safety information that must be observed at all times when working on or with the product.

To prevent personal injury and property damage and to ensure long-term operation of the product, read this section carefully and observe all safety information at all times.

### **⚠ DANGER**

#### **Danger to life due to high voltages of the PV array**

When exposed to sunlight, the PV array generates dangerous DC voltage which is present in the DC conductors and the live components of the inverter. Touching the DC conductors or the live components can lead to lethal electric shocks.

- All work on the inverter must be carried out by qualified persons only.
- Prior to performing any work on the inverter, always disconnect the inverter from voltage sources (see inverter manual).
- Do not touch any live components of the inverter.

### **⚠ CAUTION**

#### **Risk of burns due to hot inverter enclosure parts**

Some parts of the inverter enclosure can get hot during operation.

- Do not touch any parts other than the lower enclosure lid of the inverter during operation.

### **NOTICE**

#### **Damage to the inverter due to electrostatic discharge**

Touching electronic components can cause damage to or destroy the inverter through electrostatic discharge.

- Ground yourself before touching any component.

## 2.3 Symbol on the Product

### **Symbol**



### **Explanation**

Danger to life due to electric shock

The product operates at high voltages. All work on the product must be carried out by qualified persons only.



### 3 Scope of Delivery

Check the scope of delivery for completeness and any externally visible damage. Contact your distributor if the scope of delivery is incomplete or damaged.

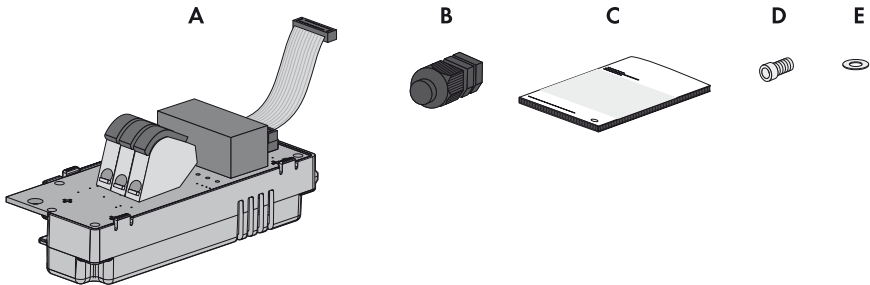

Figure 1: Components included in the scope of delivery

Position	Quantity	Designation
A	1	Multifunction relay*
B	1	M20x1.5 cable gland*
C	1	Installation manual
D	1	M4x8 cylindrical screw*
E	1	Washer M4*

\* This component is not included if the multifunction relay is installed upon delivery.

## 4 Electrical Connection

### 4.1 Safety during Electrical Connection

#### **⚠ DANGER**

##### **Danger to life due to high voltages of the PV array**

When exposed to sunlight, the PV array generates dangerous DC voltage which is present in the DC conductors and the live components of the inverter. Touching the DC conductors or the live components can lead to lethal electric shocks.

- All work on the inverter must be carried out by qualified persons only.
- Prior to performing any work on the inverter, always disconnect the inverter from voltage sources (see inverter manual).
- Do not touch any live components of the inverter.

#### **NOTICE**

##### **Damage to the inverter due to electrostatic discharge**

Touching electronic components can cause damage to or destroy the inverter through electrostatic discharge.

- Ground yourself before touching any component.

### 4.2 Electrical Connection Procedure

Procedure	See
1. Installation of the multifunction relay: Install the multifunction relay in the inverter if it is not installed in the inverter upon delivery.	Section 4.4, page 11
2. Selection of the operating mode: Select the operating mode in which you want to use the multifunction relay.	Section 4.5, page 17
3. Connection of the multifunction relay: Connect the multifunction relay based on the operating mode and the corresponding wiring diagram.	Section 4.6, page 18
4. Change of the operating mode: Change the operating mode of the multifunction relay if you do not want to operate the multifunction relay in the operating mode <b>Fault indication (FlInd)</b> and do not plan to connect a display to the multifunction relay.	Section 5, page 24

### 4.3 Overview of the Connection Area

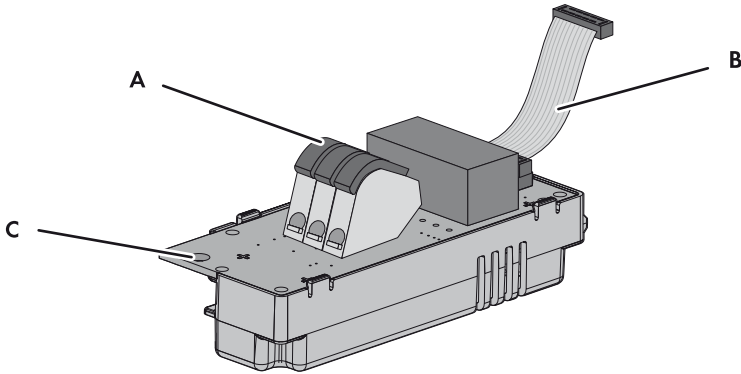

Figure 2: Design of the multifunction relay

Position	Designation
A	Connecting terminal plate for the connection to the multifunction relay
B	Ribbon cable for the connection in the inverter
C	Hole for attaching the multifunction relay in the inverter

### 4.4 Installing the Multifunction Relay

#### 4.4.1 Mounting Position and Cable Route

##### Mounting Position and Cable Route in the Sunny Tripower

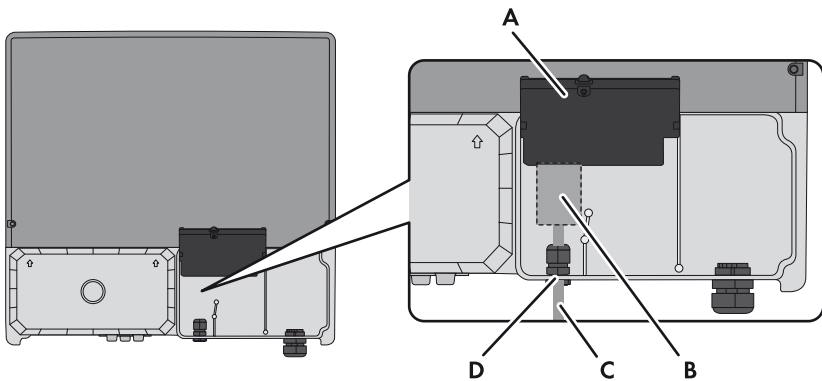

Figure 3: Installation area and cable route in the Sunny Tripower with the lower enclosure lid open and the display assembly flipped up

Position	Designation
A	Inverter display assembly
B	Installation location of the multifunction relay
C	Cable route for the connection to the multifunction relay
D	M20x1.5 cable gland

### Mounting Position and Cable Route in the Sunny Boy Smart Energy

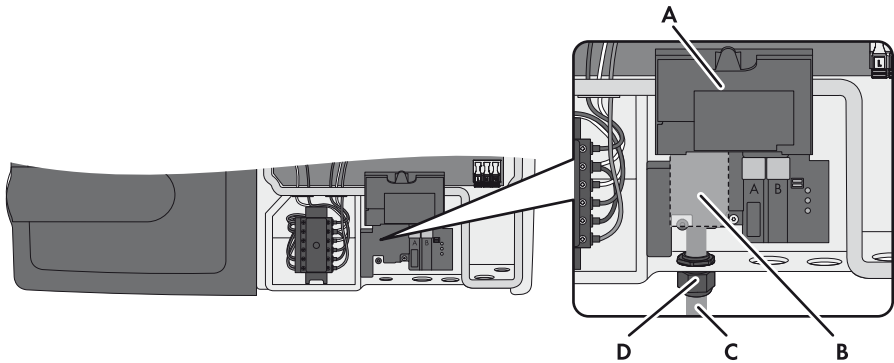

Figure 4: Installation area and cable route in the Sunny Boy Smart Energy with the enclosure lid open and the display flipped up

Position	Designation
A	Inverter display
B	Installation location of the multifunction relay
C	Cable route for the connection to the multifunction relay
D	M20x1.5 cable gland

### Mounting Position and Cable Route in the Sunny Boy / Windy Boy

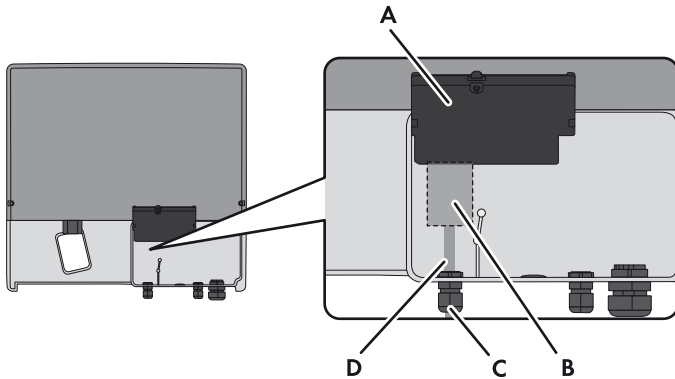

Figure 5: Installation area and cable route in the Sunny Boy/Windy Boy with the lower enclosure lid open and the display assembly flipped up

Position	Designation
A	Inverter display assembly
B	Installation location of the multifunction relay
C	Cable route for the connection to the multifunction relay
D	M20x1.5 cable gland

#### 4.4.2 Installing the Multifunction Relay in the Sunny Boy Smart Energy

1. **⚠ DANGER**

**Danger to life due to high voltages in the inverter**

- Disconnect the inverter from voltage sources and open the enclosure lid (see inverter manual).

2. Remove the display:

- Flip the display up.

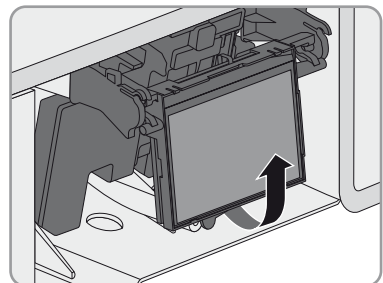

- Remove the plug of the display ribbon cable from the pin connector on the display assembly.
- Flip the display down.

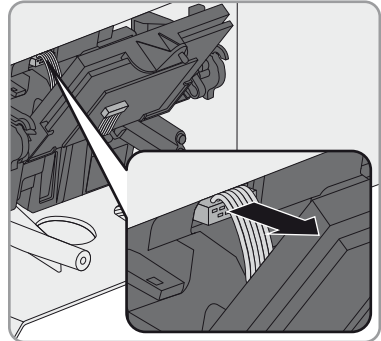

- Press the right-hand retainer outwards.
- Pull the display assembly out of the right-hand retainer.
- Pull the display assembly out of the left-hand retainer.

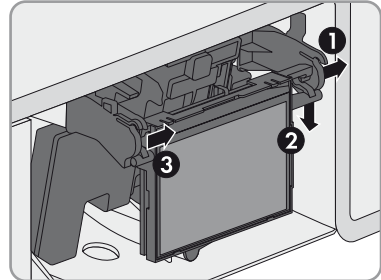

- Set the display assembly aside in a safe place.

3. Insert the ribbon cable of the multifunction relay into the pin connector on the display assembly.

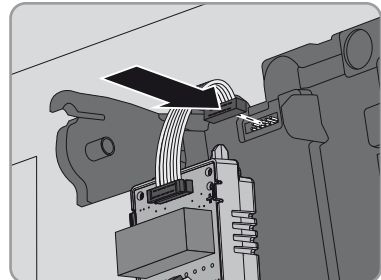

4. Insert the multifunction relay in the inverter. Lead the left-hand key on the multifunction relay into the hole in the plastic retainer for the display assembly.

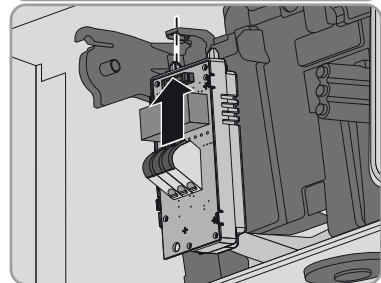

5. Fasten the multifunction relay using the washer and the cylindrical screw (torque: 1.5 Nm). Use an Allen key (AF 3).

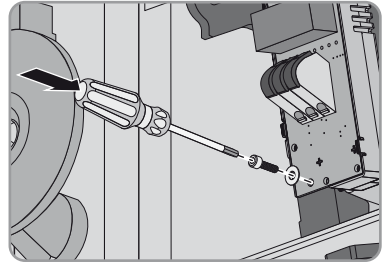

6. Install the display:
  - Plug the ribbon cable plug into the pin connector on the display assembly.
  - Lead the display into the right-hand retainer.
  - Lead the display into the left-hand retainer.

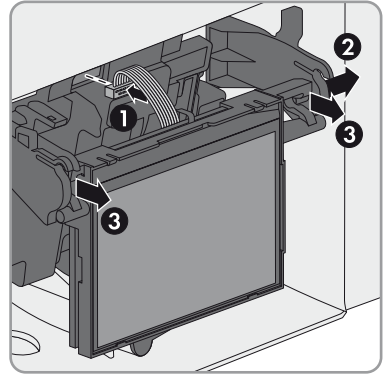

### 4.4.3 Installing the Multifunction Relay in the Sunny Boy / Windy Boy or Sunny Tripower

#### **i** Displayed graphics

This section describes the installation of the multifunction relay, but only shows the Sunny Tripower in the illustrations. The procedure for installing the multifunction relay in Sunny Boy / Windy Boy and Sunny Tripower inverters is identical. Only the inverter environment is different.

#### Procedure:

1. **⚠ DANGER**  
**Danger to life due to high voltages in the inverter**
  - Disconnect the inverter from all voltage sources and open the lower enclosure lid (see inverter manual).
2. Release the display assembly screw and flip the display assembly up.
3. The display assembly snaps into place.

4. Insert the multifunction relay in the inverter. Lead the left-hand key on the multifunction relay into the hole in the plastic retainer for the display assembly.

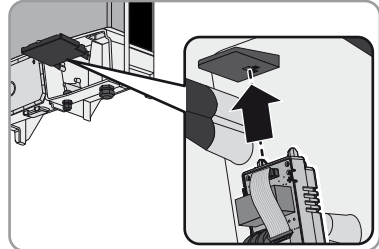

5. Lead the ribbon cable upwards behind the display assembly.

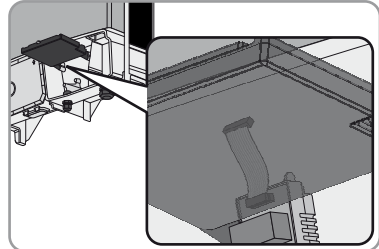

6. Fasten the multifunction relay using the washer and the cylindrical screw (torque: 1.5 Nm). Use an Allen key (AF 3).

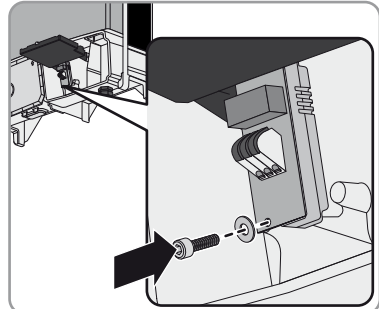

7. Flip the display assembly down.

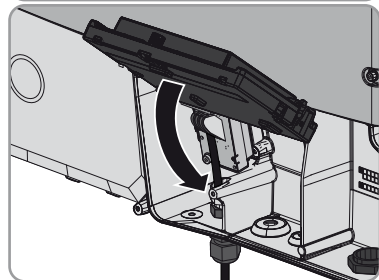

8. Tighten the screw of the display assembly.

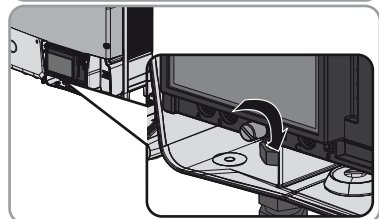



9. Insert the plug from the multifunction relay ribbon cable into the left-hand pin connector on the display assembly. You have to press apart the lock hooks on the pin connector in order to insert the plug.
- ☑ After inserting the plug, the lock hooks close.

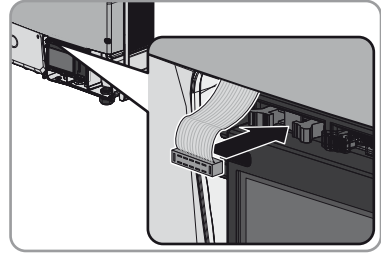

## 4.5 Selecting the Operating Mode

### **i** Error message required by standard

In some countries, signaling of errors is required by standards, e.g. IEC 62109-2. This requirement can be met in one of two ways:

- Operate the multifunction relay in the operating mode **Fault indication (FltInd)** and connect a display to the multifunction relay that signals an error or the undisturbed operation of the inverter.
- Activate the error alarm in Sunny Portal (see the Sunny Portal user manual at [www.SunnyPortal.com](http://www.SunnyPortal.com) for information on receiving error alarms via Sunny Portal). This requires the inverter to be registered on Sunny Portal.

You can choose between the following operating modes:

Operating mode of multifunction relay (Mlt.OpMod)	Description
<b>Fault indication (FltInd)</b>	The multifunction relay controls a display device which, depending on the type of connection, signals either an error or the undisturbed operation of the inverter.  This operating mode is set by default.
<b>Self-consumption (SelfCsmP)</b>	The multifunction relay switches the loads on or off depending on the amount of power available from the PV array. If a battery is integrated in the system, the multifunction relay will still switch the loads on or off depending on the amount of power available from the PV array, not from the battery.
<b>Control via communication (ComCtl)</b>	The multifunction relay switches loads on and off according to commands transmitted by a communication product.
<b>Battery bank (BatCha)</b>	The multifunction relay controls the charging of external batteries depending on the amount of power available from the system.

Operating mode of multifunction relay (Mlt.OpMod)	Description
<b>Fan control (FanCtl)</b>	The multifunction relay controls an external fan depending on the temperature of the inverter. If the temperature of the inverter is 5 °C higher than a specific threshold set in the inverter, the fan starts automatically. If the temperature of the inverter is 10 °C below the set threshold, the fan stops automatically.
<b>Switching status grid relay (GriSwCpy)</b>	The multifunction relay switches simultaneously with the grid relay of the inverter and transmits a signal to the grid operator.

## 4.6 Connecting the Multifunction Relay

### 4.6.1 Connection Options for the Multifunction Relay

There is a different connection procedure depending on which operating mode you select.

Operating mode of multifunction relay (Mlt.OpMod)	Connection option
<b>Fault indication (FltInd)</b>	Using the multifunction relay as fault indicator contact
<b>Self-consumption (SelfCsmP)</b>	Controlling loads or charging batteries in a power-dependent way via the multifunction relay
<b>Control via communication (ComCtl)</b>	Controlling loads or charging batteries in a power-dependent way via the multifunction relay
<b>Battery bank (BatCha)</b>	Controlling loads or charging batteries in a power-dependent way via the multifunction relay
<b>Fan control (FanCtl)</b>	Connecting the external fan (see fan documentation)
<b>Switching status grid relay (GriSwCpy)</b>	Reporting the switching status of the grid relay

#### Using the multifunction relay as a fault indicator contact or operation signaling contact

You can use the multifunction relay as a fault indicator contact for displaying or reporting inverter errors. This requires a parallel connection. Alternatively, you can choose to have the undisturbed operation displayed or reported. This requires a series connection. You can connect several inverters to one fault indicator contact or operation signaling contact. You must connect the multifunction relays of several inverters in parallel.

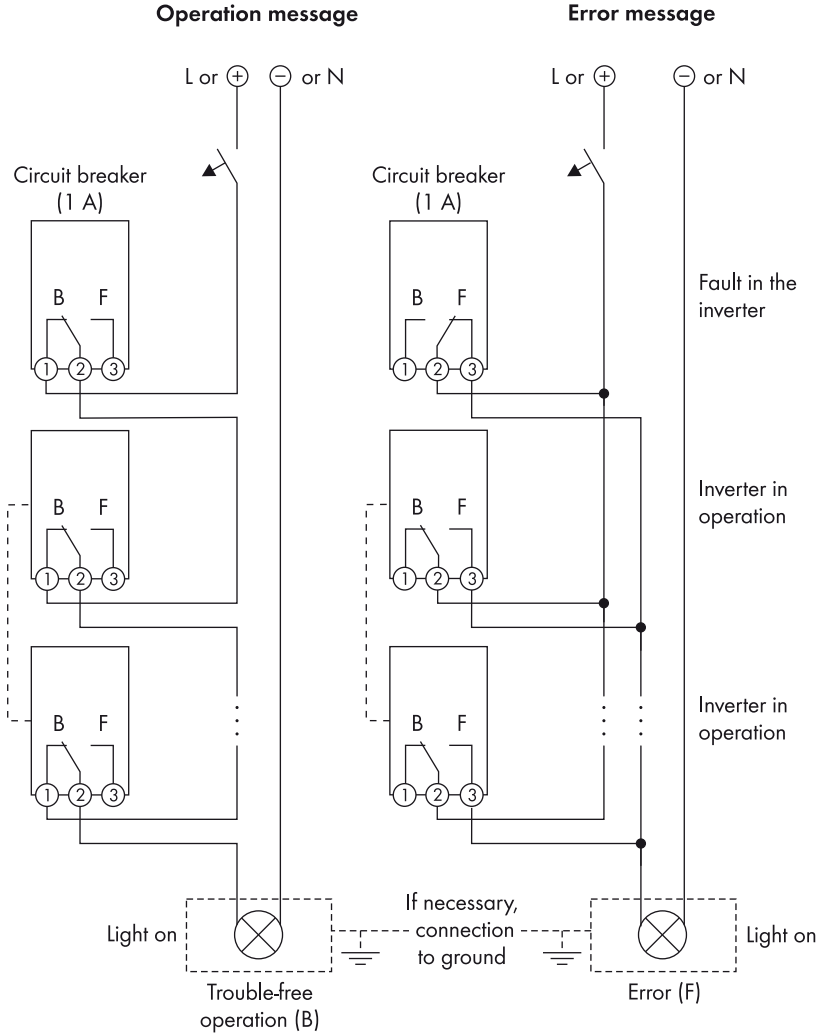

Figure 6: Wiring diagram with several inverters for connection of an operation signaling contact and wiring diagram for connection of a fault indicator contact (example)

### Controlling loads or charging external batteries in a power-dependent way via the multifunction relay

Loads can be controlled and external batteries charged in a power-dependent way via the multifunction relay. To enable this function, a contactor (K1) must be connected to the multifunction relay. The contactor (K1) switches the operating current for the load on or off. If you want external batteries to be charged depending on the available power, the contactor serves to activate or deactivate the charging of the batteries.

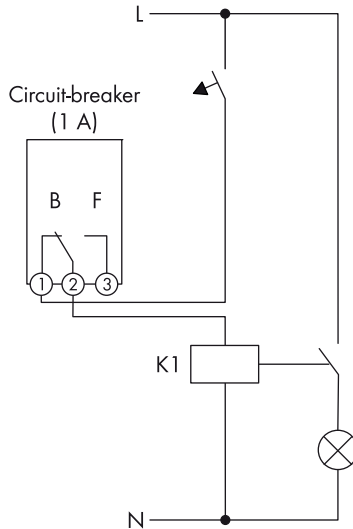

Figure 7: Wiring diagram for connection to control a load or for the power-dependent charging of the batteries

### Reporting the switching status of the grid relay

The multifunction relay can trip a signal to the grid operator as soon as the inverter connects to the utility grid. To enable this function, the multifunction relays of all inverters must be connected in parallel.

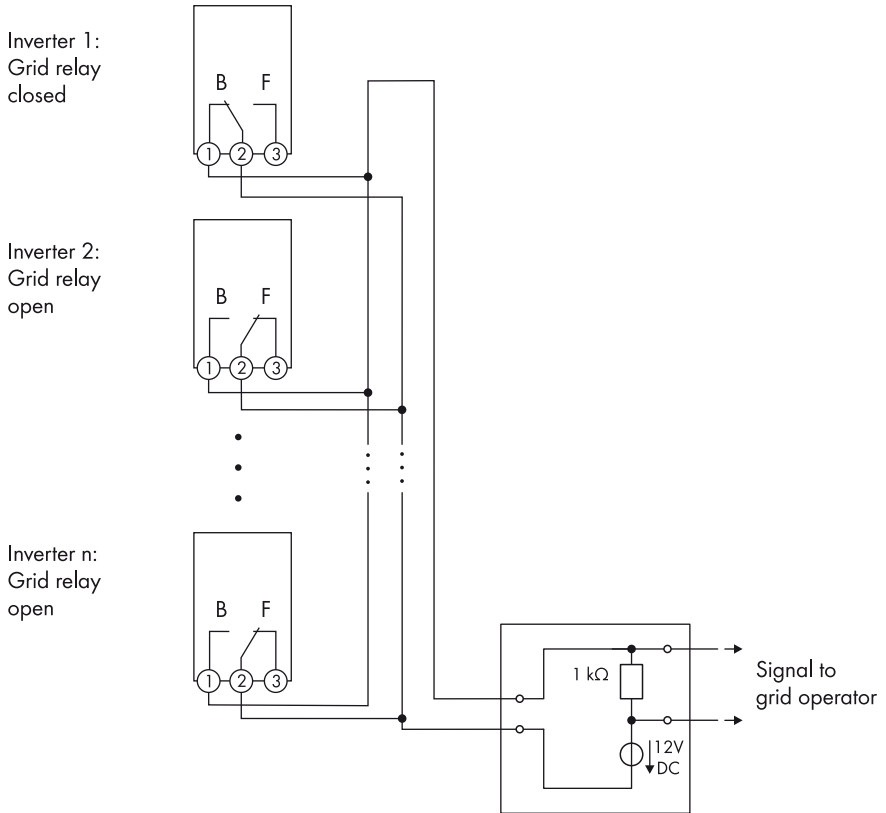

Figure 8: Wiring diagram for reporting the switching status of the grid relay (example)

## 4.6.2 Connecting to the Multifunction Relay

### Requirement:

- The technical requirements of the multifunction relay must be met (see Section 6 "Technical Data", page 25).

### Cable requirements:

- The cable must be double-insulated.
- External diameter: 5 mm to 12 mm
- Conductor cross-section: 0.08 mm<sup>2</sup> to 2.5 mm<sup>2</sup>
- The cable type and cable-laying method must be appropriate for the installation and location.

### NOTICE

#### Destruction of the multifunction relay as a result of excessive contact load

- Observe the maximum switching voltage and maximum switching current (see Section 6 "Technical Data", page 25).
- When connecting the multifunction relay to the utility grid, protect the multifunction relay with a separate circuit breaker.

### **i** Displayed graphics

This section describes the connection to the multifunction relay, but only shows the Sunny Tripower in the illustrations. However, the same method is used to connect to the multifunction relay in all the inverters. Only the inverter environment is different.

### Procedure:

1. When connecting to the utility grid, protect the multifunction relay with a separate circuit breaker.

2. **⚠ DANGER**

#### Danger to life due to high voltages in the inverter

- Disconnect the inverter from voltage sources (see inverter manual).
3. If the cable gland on the inverter is installed inside the inverter, insert the cable gland from the outside:
    - Unscrew the counter nut from the outside of the inverter and remove the cable gland from inside of the inverter.

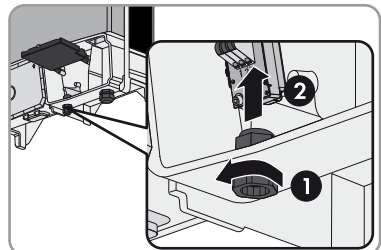

- Insert the cable gland from the outside into the enclosure opening and tighten it from the inside using the counter nut.

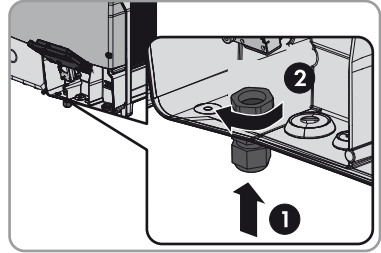

4. Slightly loosen the swivel nut of the cable gland and remove the sealing plug.
5. If the diameter of the connection cable is more than 8 mm, remove the internal seal insert from the cable gland.
6. Route the cable into the inverter through the cable gland.
7. Dismantle the cable by no more than 15 mm.
8. Strip off the insulation of the conductors by no more than 8 mm.

9. Depending on the intended use (operating mode), connect the cable to the connecting terminal plate for connecting to the multifunction relay in accordance with the wiring diagram.

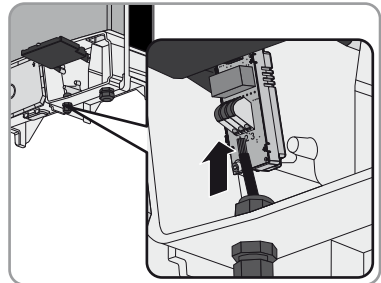

10. Tighten the swivel nut of the cable gland.

11. Flip the display down.

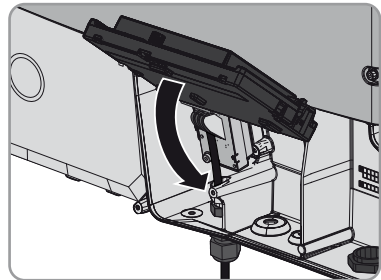

12. For Sunny Tripower or Sunny Boy / Windy Boy inverters: Tighten the screw of the display assembly.

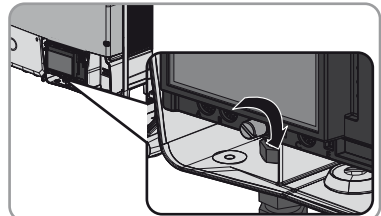

13. Recommission the inverter (see inverter manual).

## 5 Changing the Operating Mode of the Multifunction Relay

The default operating mode of the multifunction relay is **Fault indication (FltInd)**. If you decide to use another operating mode and have established the correct electrical connection for this operating mode, you will have to change the operating mode of the multifunction relay and make other settings, if necessary (see the communication product manual for more information on changing parameters).

### Requirement:

- The inverter must be connected to a communication product via BLUETOOTH or Speedwire/Webconnect.

### Procedure:

1. Call up the user interface of the communication product or Sunny Explorer and log in as **Installer**.
2. Select the parameter **Operating mode of multifunction relay/Mlt.OpMode** and set the desired operating mode.
3. Once you have set the operating mode **Self-consumption**, make the following additional settings:
  - Select the parameter **Minimum On power for MFR self-consumption/Mlt.MinOnPwr** and set the desired value. This determines the power threshold at which a load is switched on.
  - Select the parameter **Minimum power On time, MFR self-consumption/Mlt.MinOnPwrTmm** and set the desired value. This determines the minimum time for which the power must exceed the minimum switch-on power threshold before the load is switched on.
  - Select the parameter **Minimum On time for MFR self-consumption/Mlt.MinOnTmm** and set the desired value. This determines the minimum time for which the load remains switched on.
4. If you have set the operating mode **Control via communication**, select the parameter **Status of MFR with control via communication/Mlt.ComCtl.Sw** and set the desired value. This determines the status used when the multifunction relay is controlled via a communication product.
5. If you have set the operating mode **Battery bank**, make the following additional settings:
  - Select the parameter **Minimum On power for MFR battery bank/Blt.BatCha.Pwr** and set the desired value. This determines the power threshold at which the battery is supposed to be charged.
  - Select the parameter **Minimum time before reconnection of MFR battery bank/Blt.BatCha.Tmm** and set the desired value. This sets the minimum time which must elapse after charging the battery before battery charging can resume.



## 6 Technical Data

Maximum AC switching voltage	240 V
Maximum DC switching voltage	30 V
Maximum AC switching current	1.0 A
Maximum DC switching current	1.0 A
Minimum electrical endurance when the maximum switching voltage and maximum switching current are complied with*	1,000,000 switching cycles

\* Corresponds to 20 years at 12 switching operations per day

## 7 Contact

If you have technical problems concerning our products, please contact the SMA Service Line. We need the following information in order to provide you with the necessary assistance:

- Inverter device type
- Inverter serial number
- Inverter firmware version
- Special country-specific settings of the inverter (if applicable)
- Type and number of PV modules connected
- Mounting location and altitude of the inverter
- Inverter message
- Optional equipment, e.g. communication products
- Application (operating mode) of the multifunction relay

Australia	SMA Australia Pty Ltd. Sydney	Toll free for Australia:	1800 SMA AUS (1800 762 287)
		International:	+61 2 9491 4200
Belgien/ Belgique/ België	SMA Benelux BVBA/SPRL Mechelen	+32 15 286 730	
Brasil	Vide Espanha (Espanha)		
Česko	SMA Central & Eastern Europe s.r.o. Praha	+420 235 010 417	
Chile	Ver España		
Danmark	Se Deutschland (Tyskland)		

Deutschland	SMA Solar Technology AG Niestetal	Medium Power Solutions Wechselrichter: +49 561 9522-1499 Kommunikation: +49 561 9522-2499 SMA Online Service Center: <a href="http://www.SMA.de/Service">www.SMA.de/Service</a>
		Hybrid Energy Solutions Sunny Island: +49 561 9522-399 PV-Diesel +49 561 9522-3199 Hybridsysteme:
		Power Plant Solutions Sunny Central: +49 561 9522-299
España	SMA Ibérica Tecnología Solar, S.L.U. Barcelona	Llamada gratuita en España: 900 14 22 22 Internacional: +34 902 14 24 24
France	SMA France S.A.S. Lyon	Medium Power Solutions Onduleurs : +33 472 09 04 40 Communication : +33 472 09 04 41
		Hybrid Energy Solutions Sunny Island : +33 472 09 04 42
		Power Plant Solutions Sunny Central : +33 472 09 04 43
India	SMA Solar India Pvt. Ltd. Mumbai	+91 22 61713888
Italia	SMA Italia S.r.l. Milano	+39 02 8934-7299
Κύπρος/ Kıbrıs	Βλέπε Ελλάδα/ Bkz. Ελλάδα (Yunanistan)	
Luxemburg/ Luxembourg	Siehe Belgien Voir Belgique	
Magyarország	lásd Česko (Csehország)	
Nederland	zie Belgien (België)	
Österreich	Siehe Deutschland	
Perú	Ver España	
Polska	Patrz Česko (Czechy)	

Portugal	SMA Solar Technology Portugal, Unipessoal Lda Lisboa	Gratuito em Portugal: Internacional:	800 20 89 87  +351 2 12 37 78 60
România	Vezi Česko (Cehia)		
Schweiz	Siehe Deutschland		
Slovensko	pozri Česko (Česká republika)		
South Africa	SMA Solar Technology South Africa Pty Ltd. Centurion (Pretoria)	08600 SUNNY (08600 78669) International:	+27 (12) 643 1785
United Kingdom	SMA Solar UK Ltd. Milton Keynes	+44 1908 304899	
Ελλάδα	SMA Hellas AE Αθήνα	801 222 9 222 International:	+30 212 222 9 222
България	Вижте Ελλάδα (Гърция)		
ไทย	SMA Solar (Thailand) Co., Ltd. กรุงเทพฯ	+66 2 670 6999	
대한민국	SMA Technology Korea Co., Ltd. 서울	+82 2 508-8599	
+971 2 234-6177	SMA Middle East LLC أبو ظبي		الإمارات العربية المتحدة
Other countries	International SMA Service Line Niestetal	Toll free worldwide: 00800 SMA SERVICE (+800 762 7378423)	

## 8 EC Declaration of Conformity

within the meaning of EC directives

- 2004/108/EC (electromagnetic compatibility, EMC)
- 2006/95/EC (Low voltage, LVD)
- 1999/5/EC (Radio and Telecommunications Terminal Equipment, R&TTE)

SMA Solar Technology AG hereby declares that the assembly described in this document is in compliance with the essential requirements and other relevant provisions of the aforementioned directives when used as intended with inverters from the Sunny Boy and Sunny Tripower device families. The complete EC Declaration of Conformity can be found at [www.SMA-Solar.com](http://www.SMA-Solar.com).







**SMA Solar Technology**

**[www.SMA-Solar.com](http://www.SMA-Solar.com)**

