



SHIFTING THE LIMITS



**FIND YOUR
OPERATING MANUALS**



www.fronius.com/energy-package-manuals

Fronius Solar Battery Installation



Fronius Solar Battery Installation

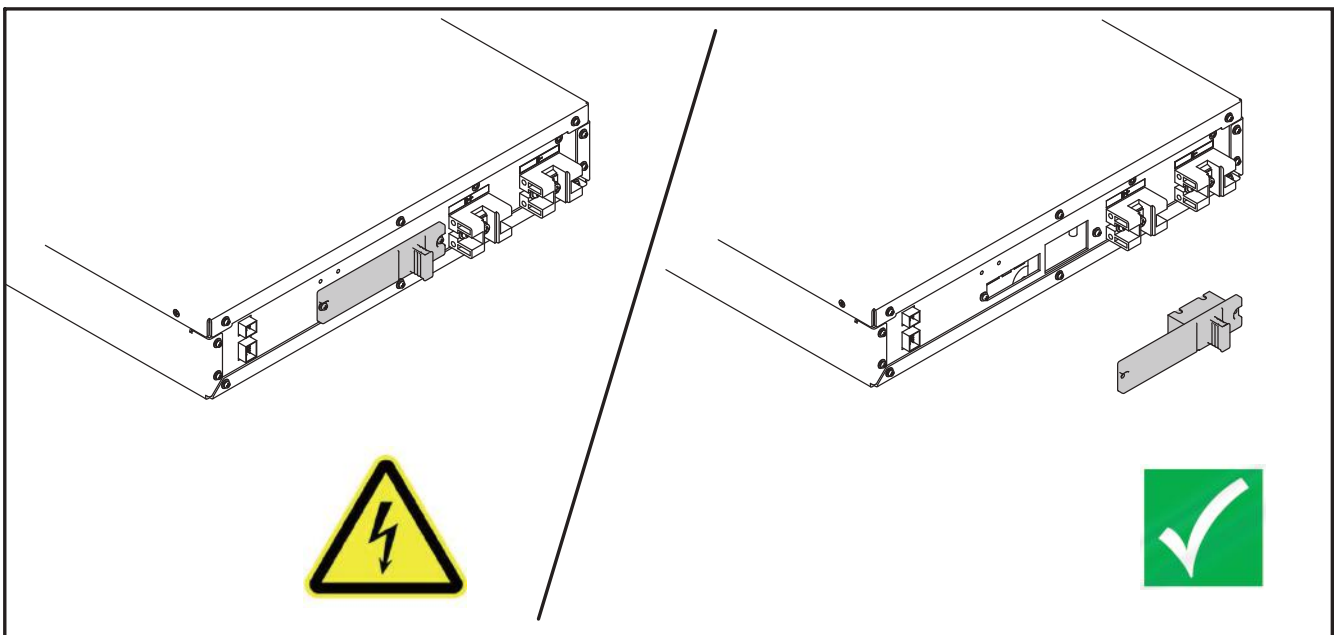
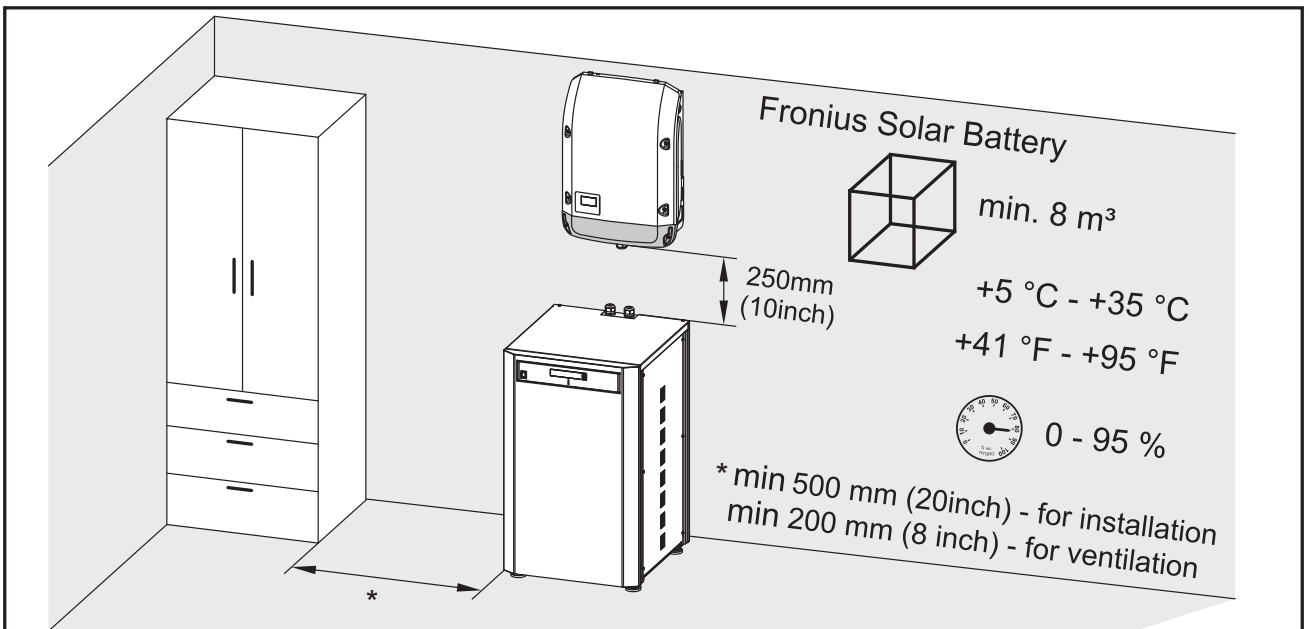
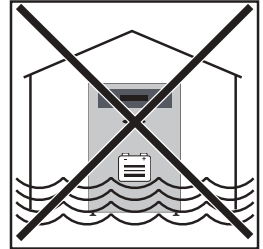
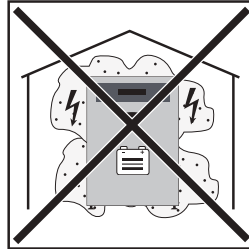
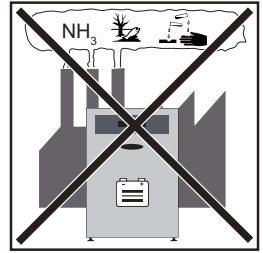
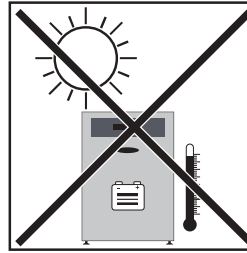
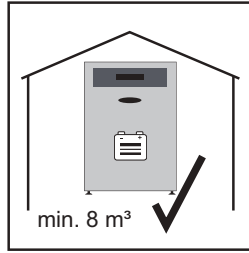

DE	Die Batteriemodule können von links oder rechts eingebaut werden. Um die Übersichtlichkeit zu bewahren, wird in dieser Anleitung nur der Einbau von der rechten Seite dargestellt.
EN	The battery modules can be installed from the left or right side. In order to preserve the clarity, the installation in the manual is represented only from the right side.
FR	Les modules de batterie peuvent être installés par la gauche ou par la droite. Par souci de clarté, seule l'installation par le côté droit est représentée dans les Instructions de service.
ES	Los módulos de batería se pueden montar desde la izquierda o desde la derecha. Para mayor claridad, este manual solo muestra el montaje desde el lado derecho.
IT	I moduli batteria possono essere installati da sinistra o da destra. Per maggiore chiarezza in queste istruzioni viene illustrata solo l'installazione dal lato destro.
NL	De accumulaties kunnen vanaf de linker- of rechterkant ingebouwd worden. Om het overzicht te behouden, wordt in deze gebruiksaanwijzing alleen de inbouw vanaf de rechterkant weergegeven.
DA	Batterimodulerne kan monteres fra venstre eller højre. For overskuelighedens skyld vises monteringen kun fra højre side i denne vejledning.
EL	Οι μονάδες μπαταρίας μπορούν να τοποθετηθούν από αριστερά ή από δεξιά. Για λόγους σαφήνειας, σε αυτές τις οδηγίες απεικονίζεται μόνο η τοποθέτηση από τη δεξιά πλευρά.
HU	Az akkumulátormodulok balról vagy jobbról szerelhetők be. Az áttekinthetőség megtartása érdekében, az útmutató csak a jobb oldali beszerelést ismerteti.
TR	Pil modülleri soldan veya sađdan kurulabilir. Genel bakýþý korumak için bu talimatta kurulum sadece sađ taraftan gösterilir.
PL	Moduły akumulatorowe można instalować z lewej lub prawej strony. Aby zagwarantować przejrzystość, w niniejszej instrukcji przedstawiono montaż tylko z prawej strony.
CS	Akkumulátorové moduly je možné vestavět zleva nebo zprava. Pro lepší přehlednost je v tomto návodu k obsluze zobrazena pouze vestavba z pravé strany.
SK	Moduly akumulátorov je možné nainštalovať zľava alebo sprava. Pre zachovanie prehľadnosti sa v tomto návode zobrazuje iba inštalácia z pravej strany.
PB	Os módulos de bateria podem ser instalados pela esquerda ou pela direita. Para preservar a visibilidade, somente é representada nesta instrução a instalação pelo lado direito.
SV	Batterimodulerna kan monteras från vänster eller från höger. För att bevara översiktligheten visas bara monteringen från höger i den här bruksanvisningen.

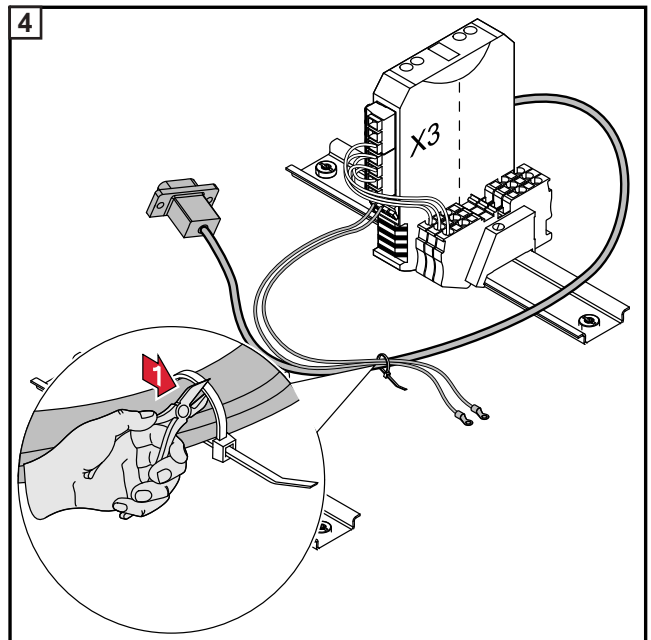
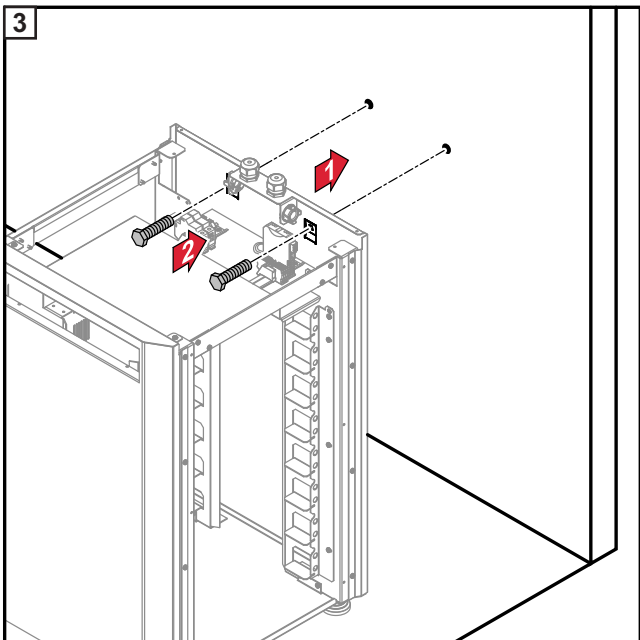
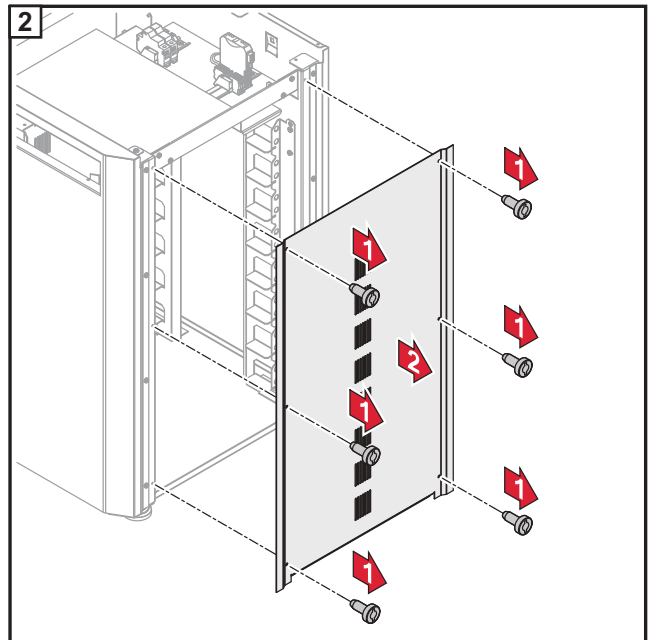
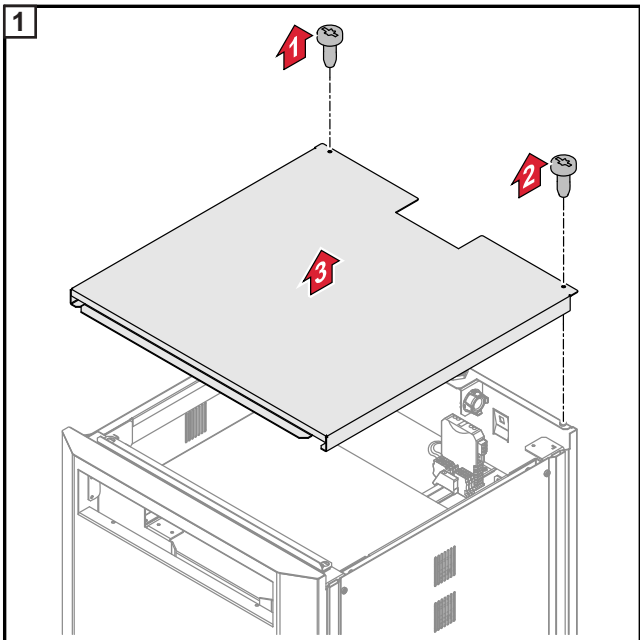

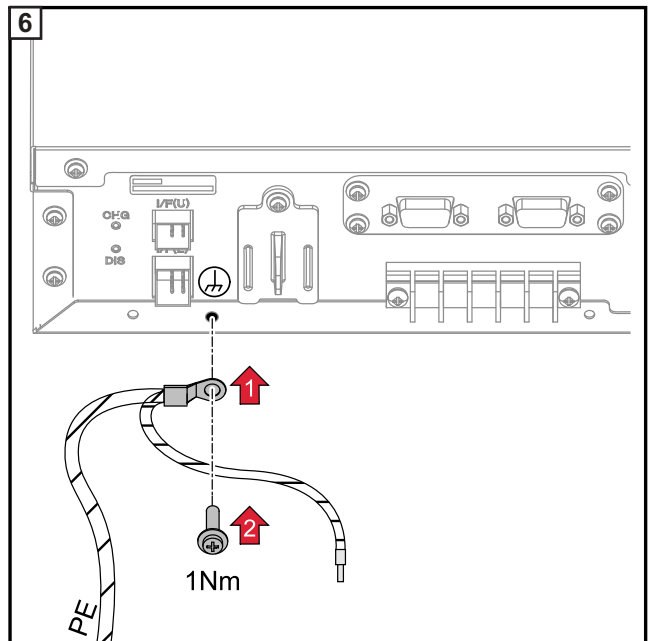
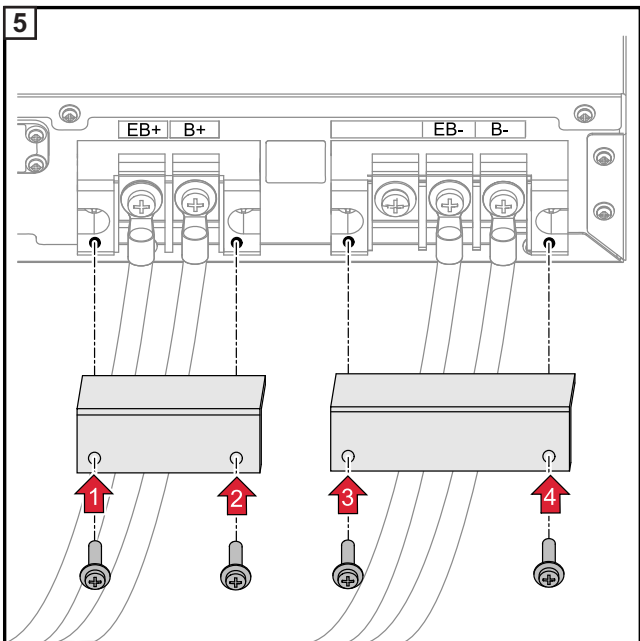
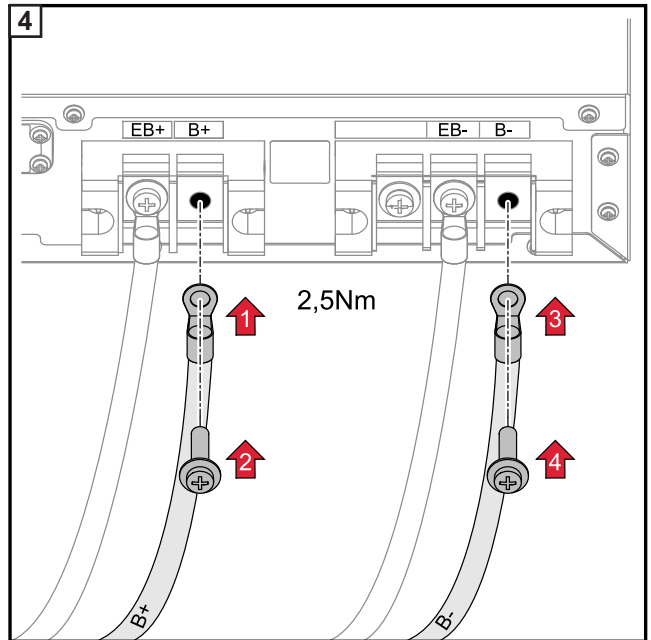
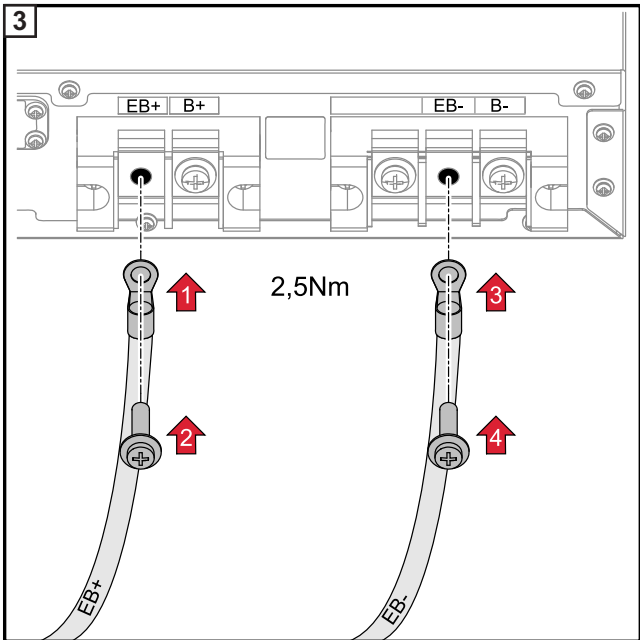
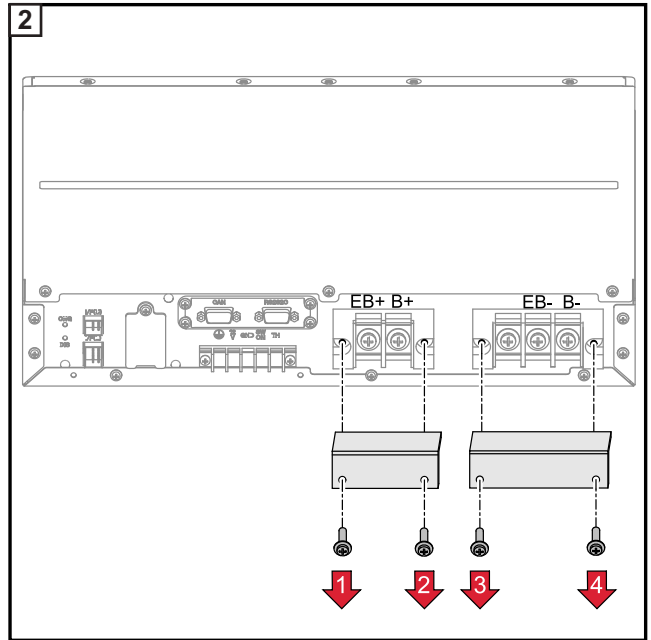
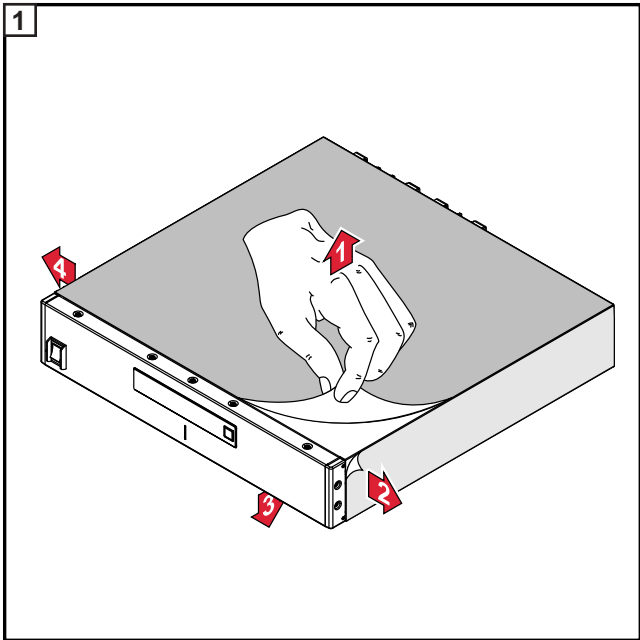

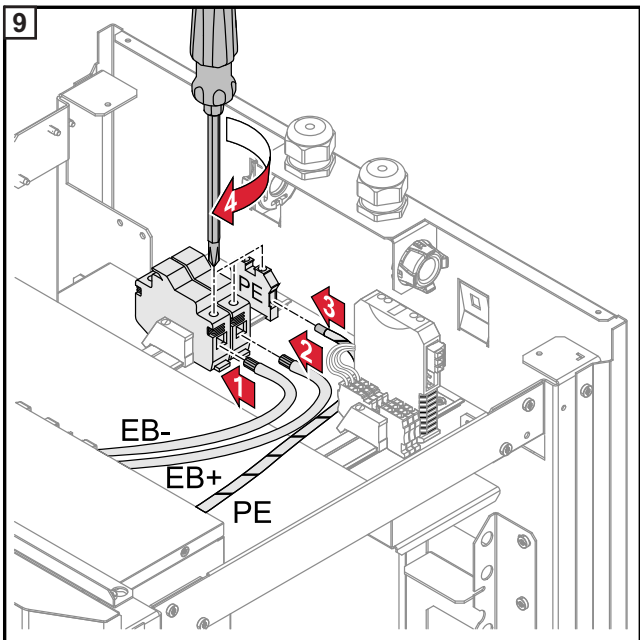
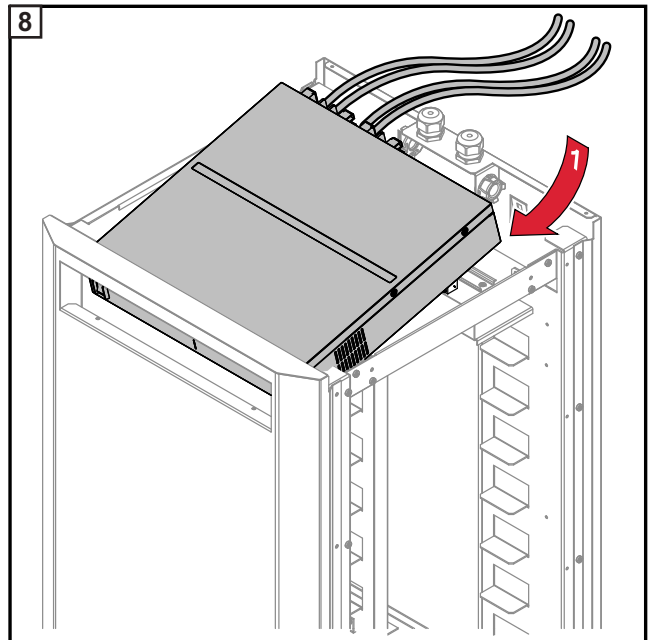
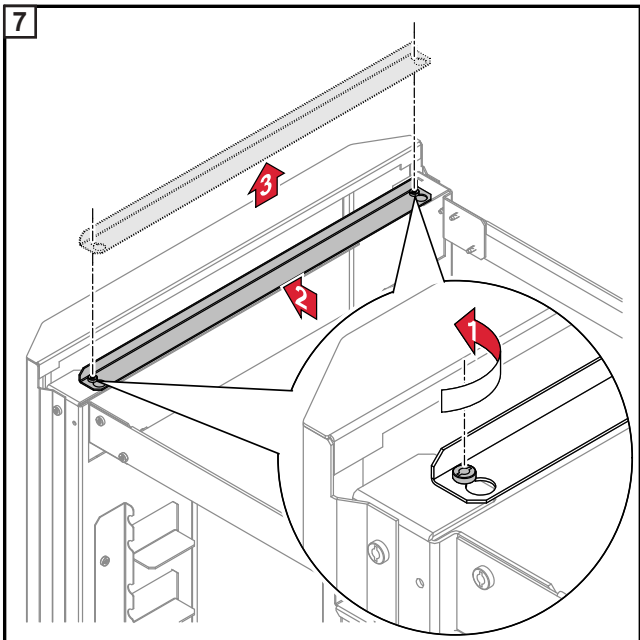

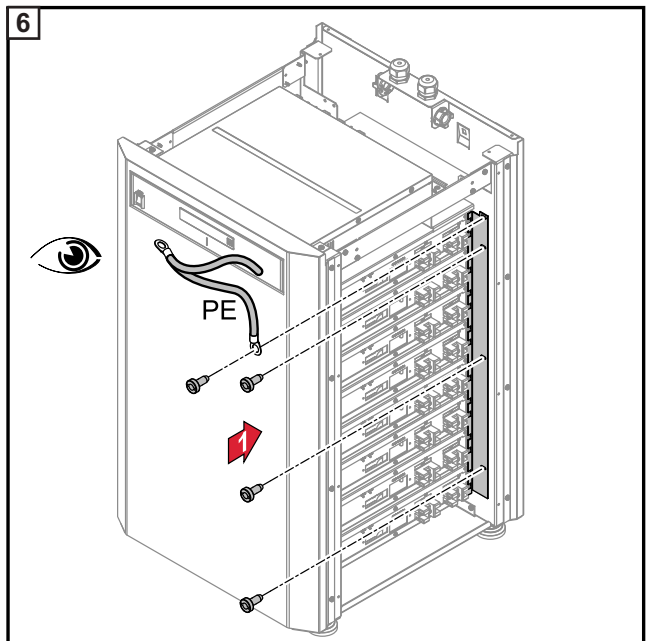
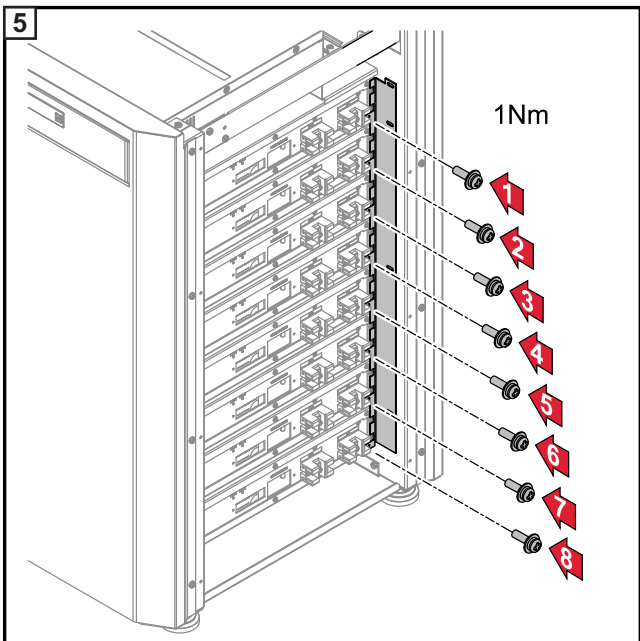
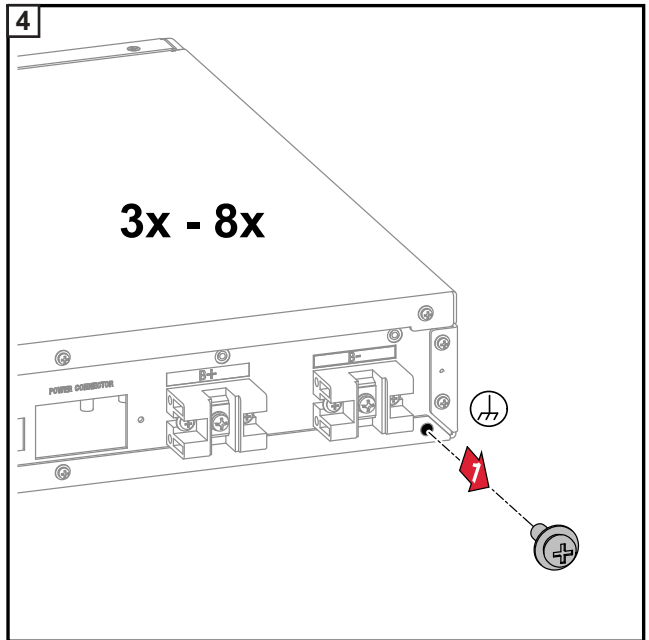
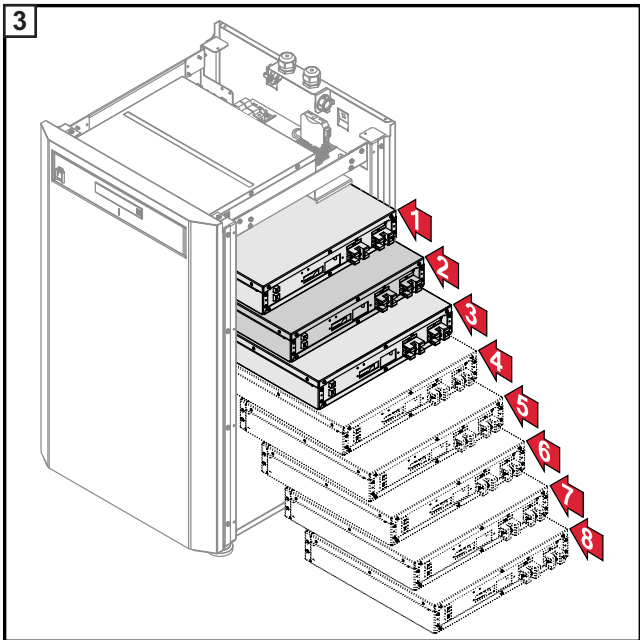
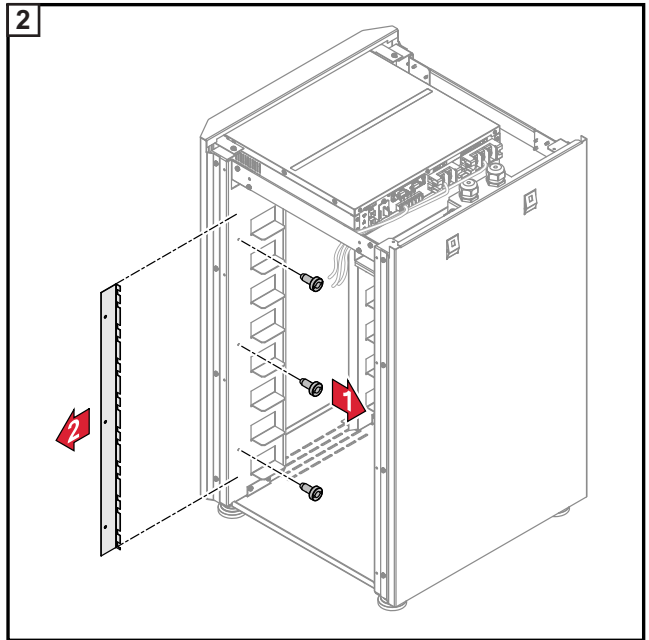
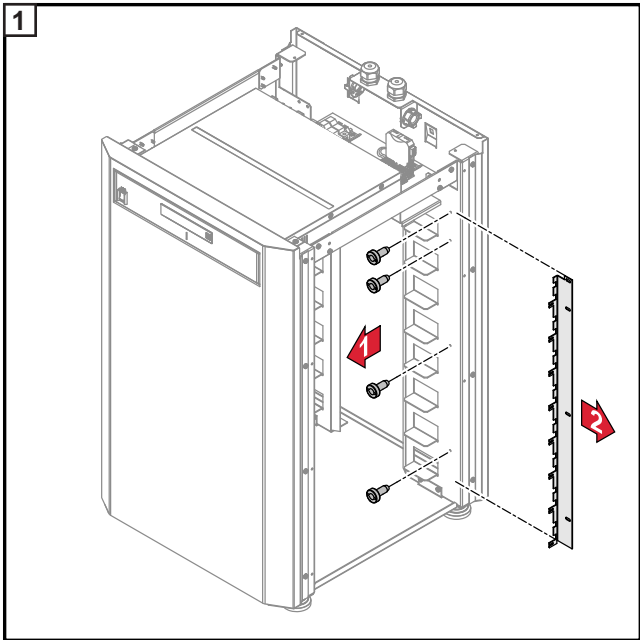

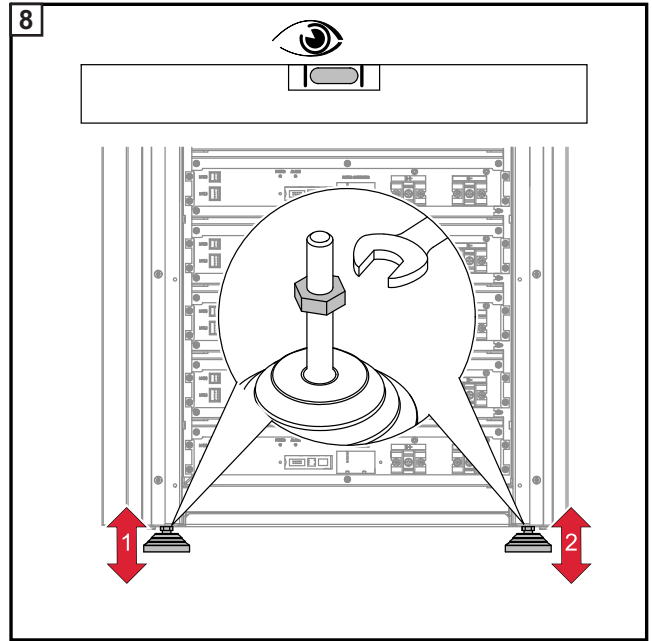
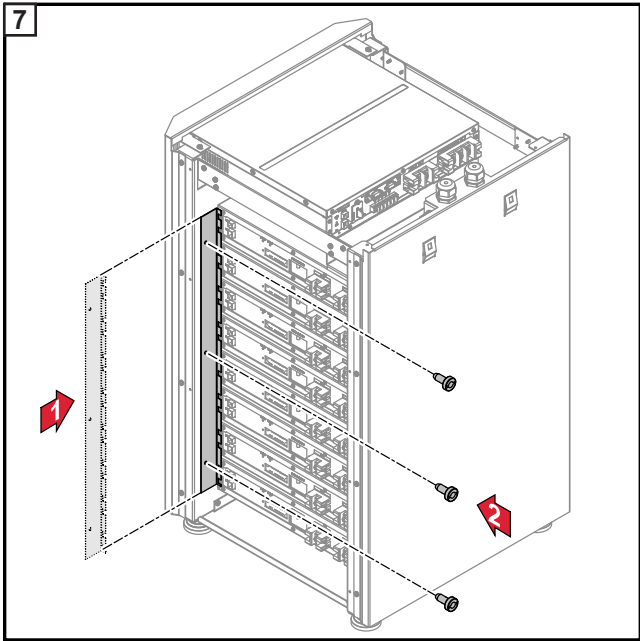

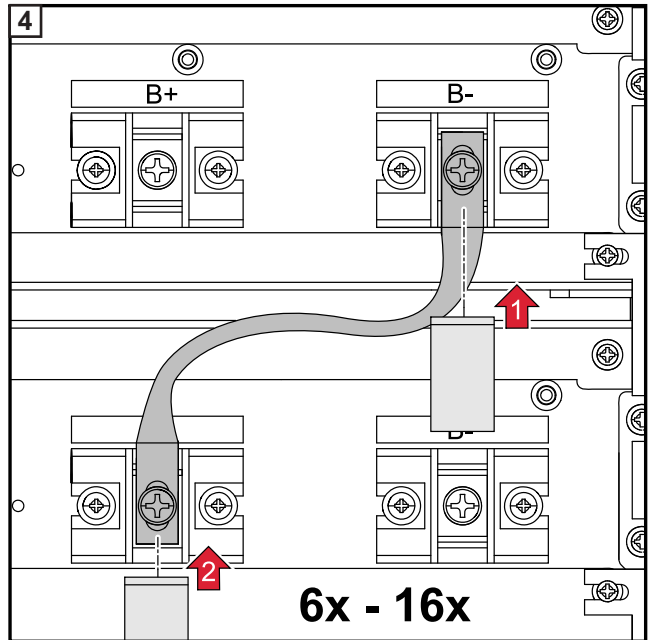
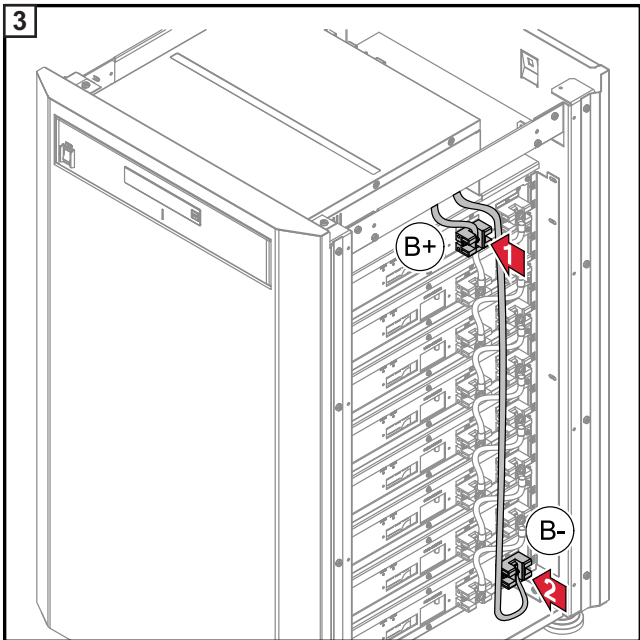
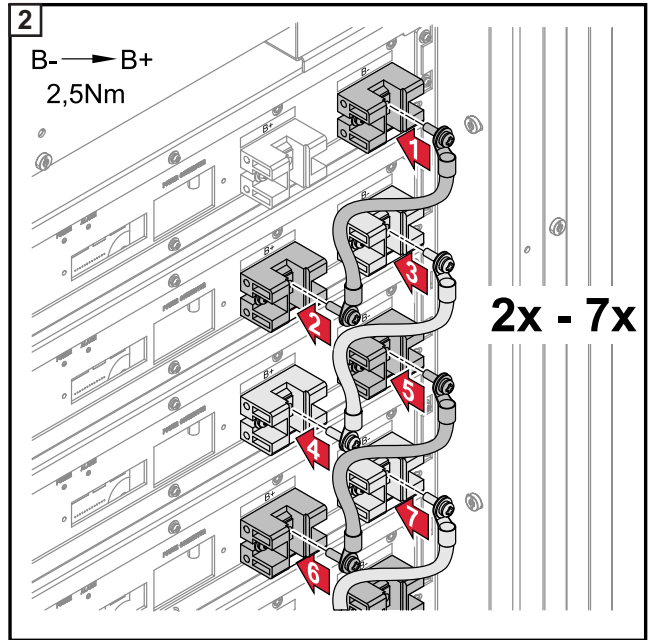
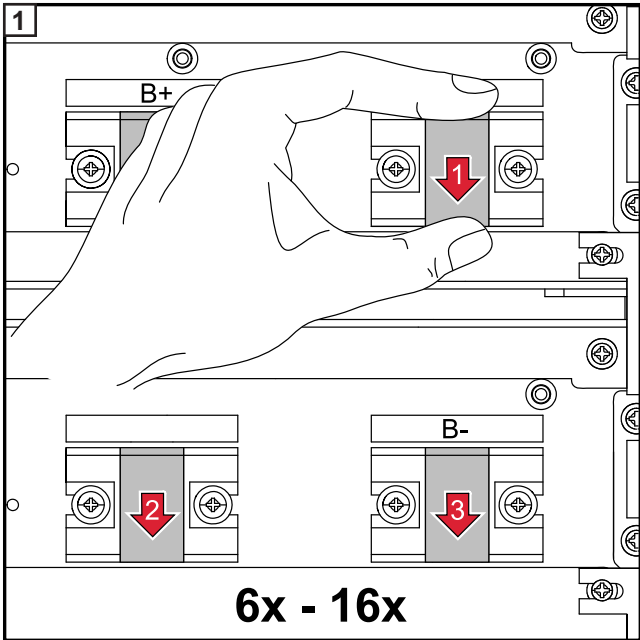

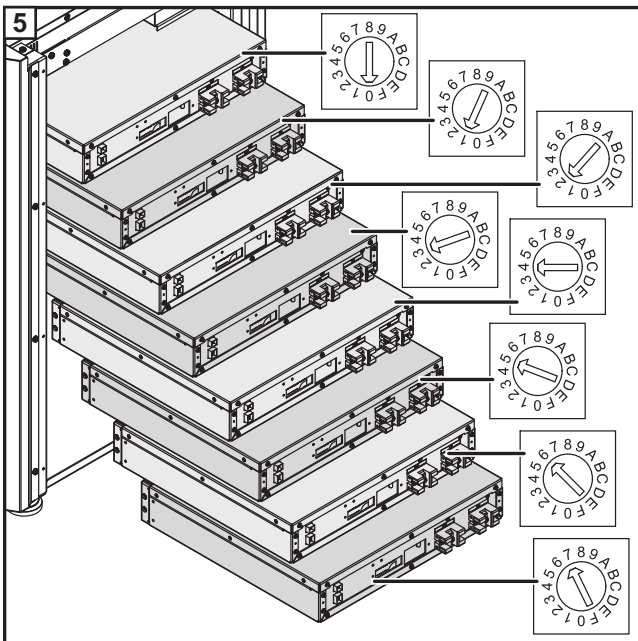
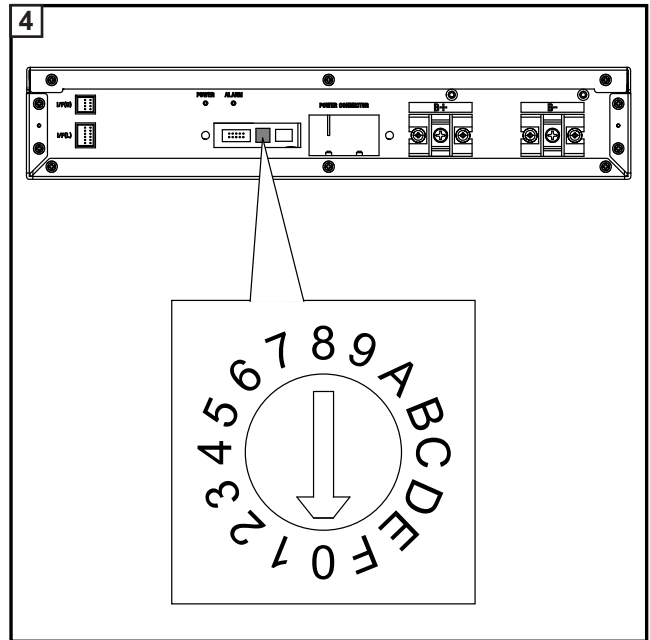
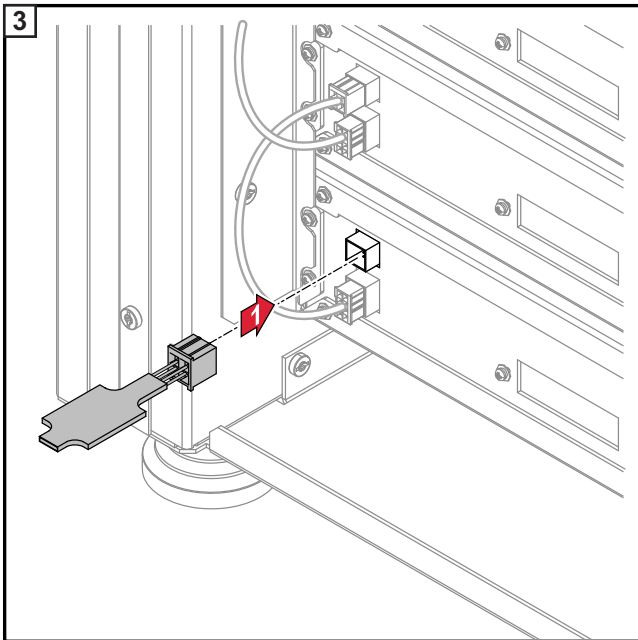
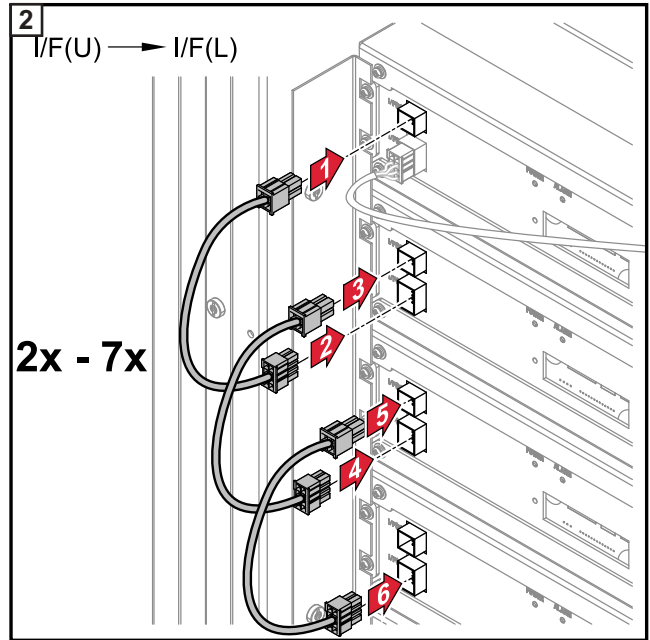
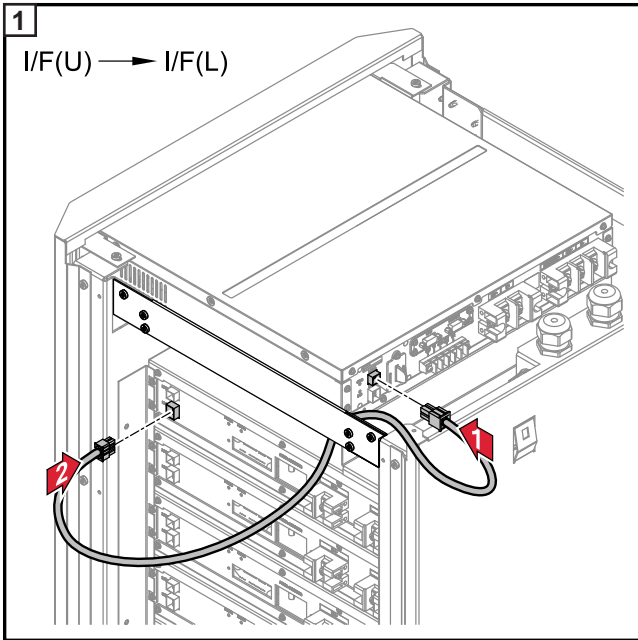

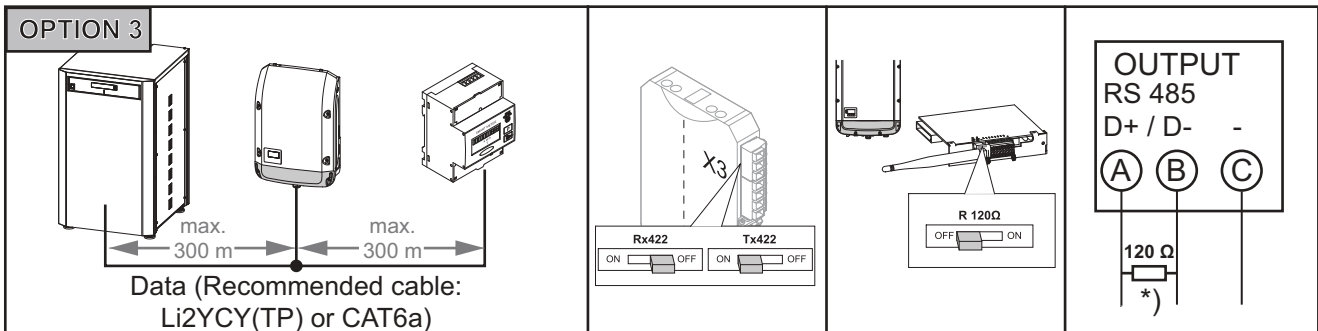
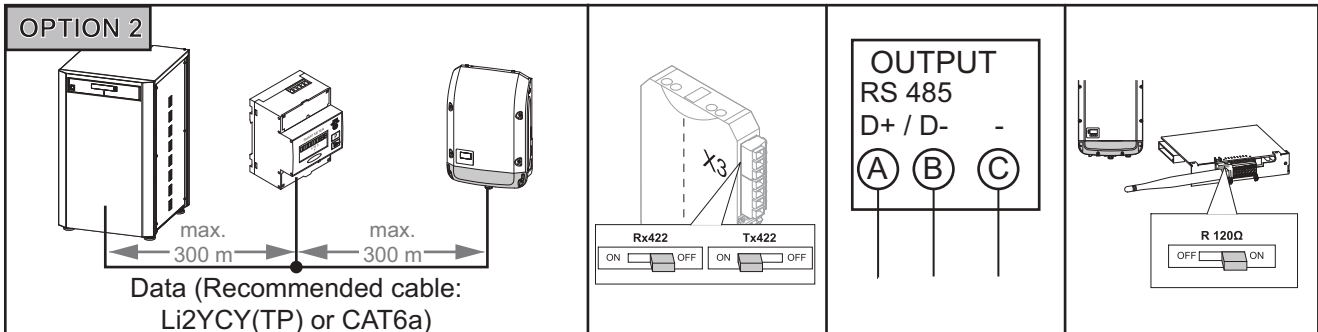
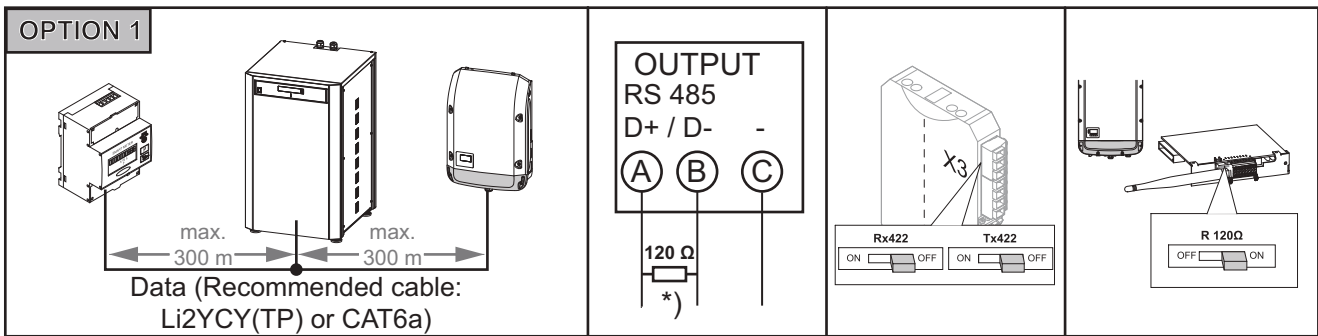

DE *) Abschlusswiderstand R 120 Ohm liegt beim Fronius Smart Meter bei

EN *) Terminating resistor R 120 is supplied with the Fronius Smart Meter

FR *) Le Fronius Smart Meter dispose d'une résistance terminale de R 120 Ohm

ES *) La resistencia final R 120 ohmios se encuentra junto al Fronius Smart Meter

IT *) La resistenza terminale R 120 Ohm è inclusa con Fronius Smart Meter

NL *) Afsluitweerstand R 120 ohm wordt bij Fronius Smart Meter meegeleverd

DA *) Afslutningsmodstand R 120 ohm er vedlagt Fronius Smart Meter

EL *) Η αντίσταση τερματισμού R 120 Ω στο Fronius Smart Meter είναι

HU *) A Fronius Smart Meter R 120 Ohm lezáró ellenállással rendelkezik

TR *) Sonlandırma direnci R 120 Ohm'ın Fronius Smart Meter'de düzeyi

PL *) Terminator R 120 Ω jest dołączony do urządzenia „Fronius Smart Meter”

CS *) Zakočovací odpor R 120 Ohm je přiložen k elektroměru Fronius Smart Meter

SK *) Zakočovací odpor R 120 ohmov je pri Fronius Smart Meter

PB *) Está anexada a resistência de conexão R de 120 Ohm no Fronius Smart Meter

SV *) Ett avslutningsmotstånd R 120 ohm följer med Fronius Smart Meter

FI *) päätevastus R 120 Ohm sisältyy Fronius Smart Meter -mittarin toimitukseen

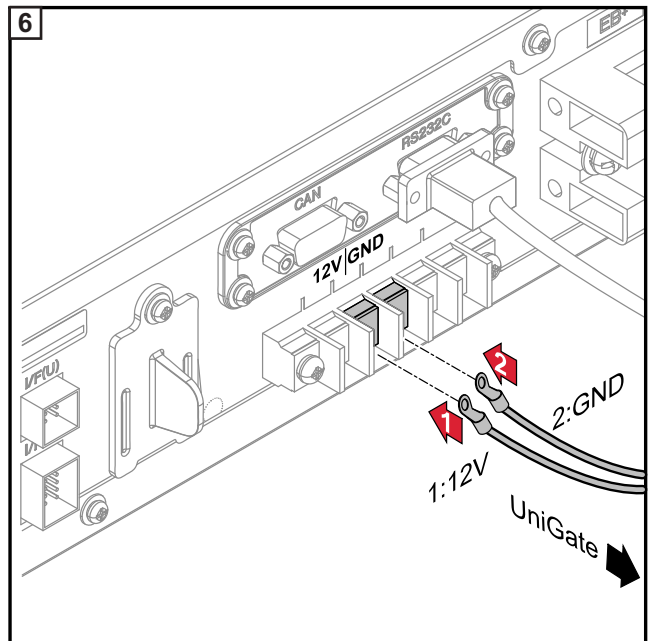
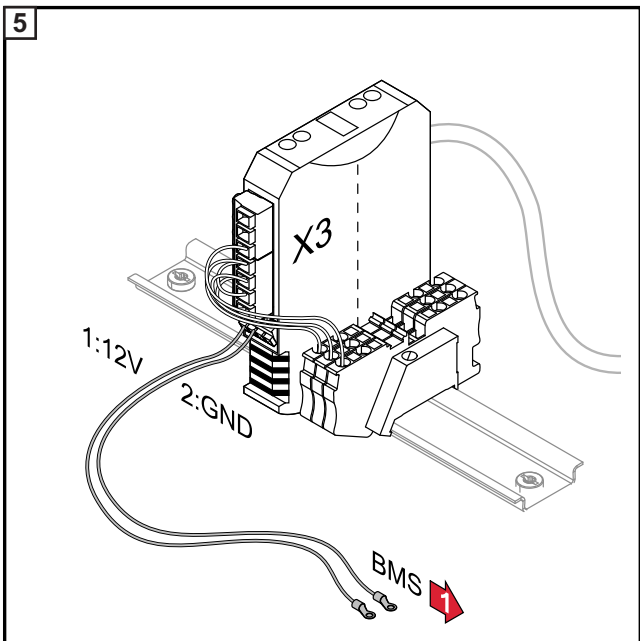
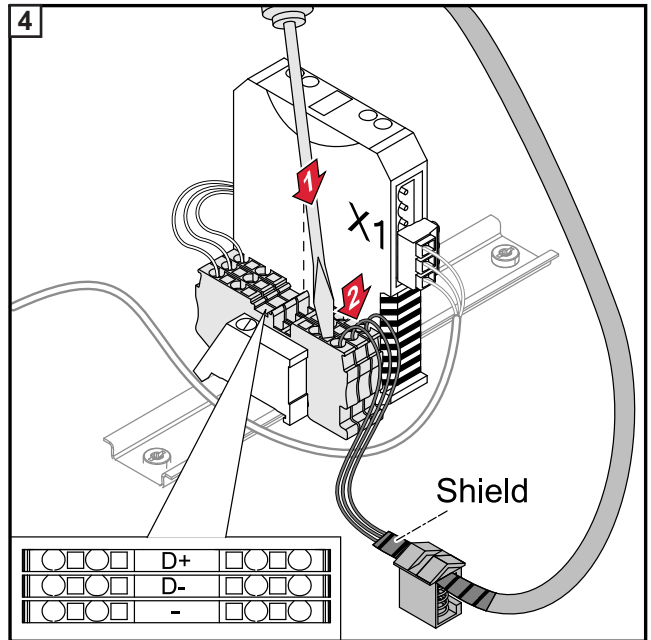
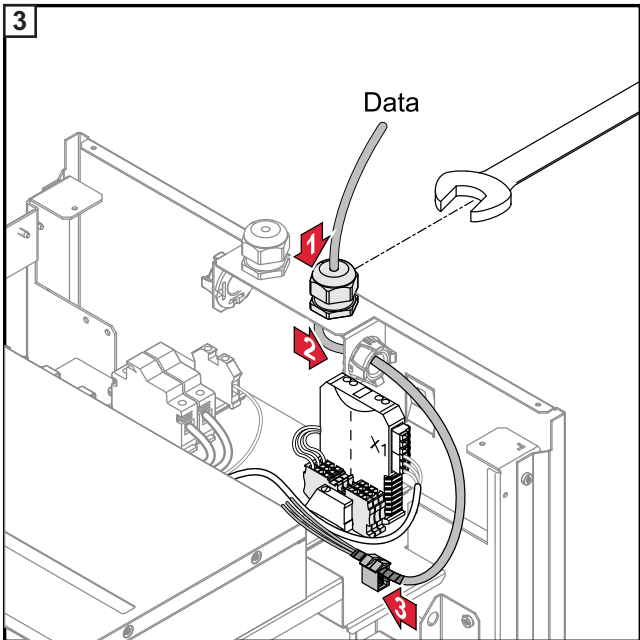
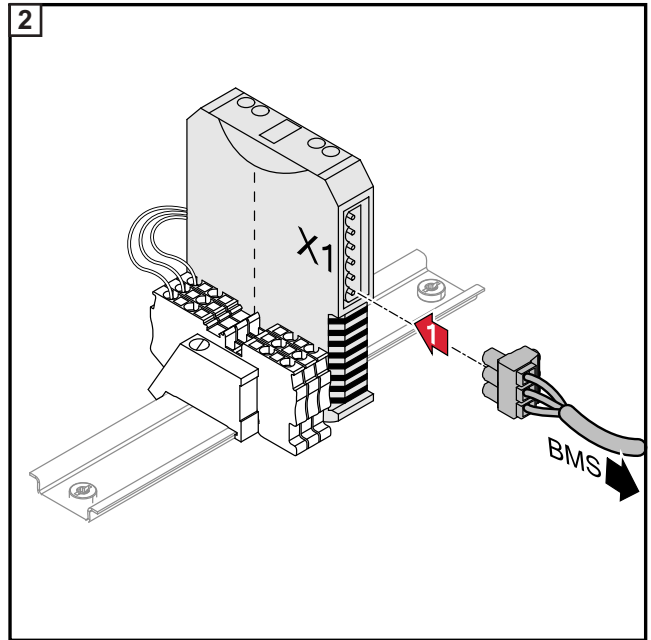
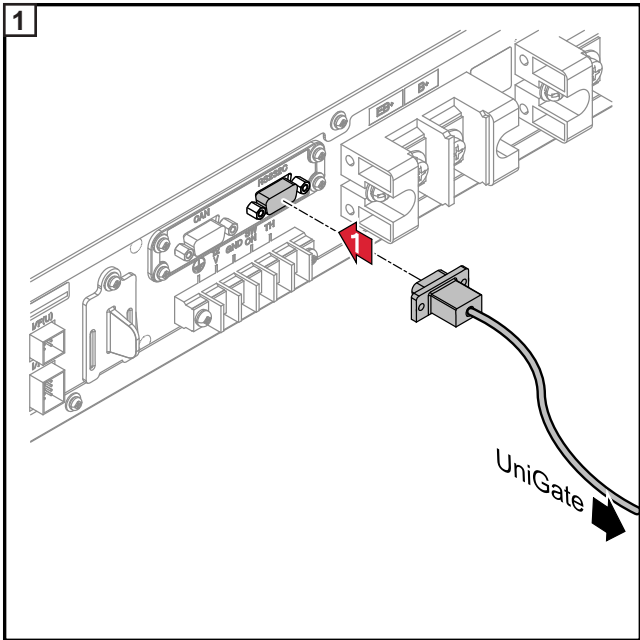

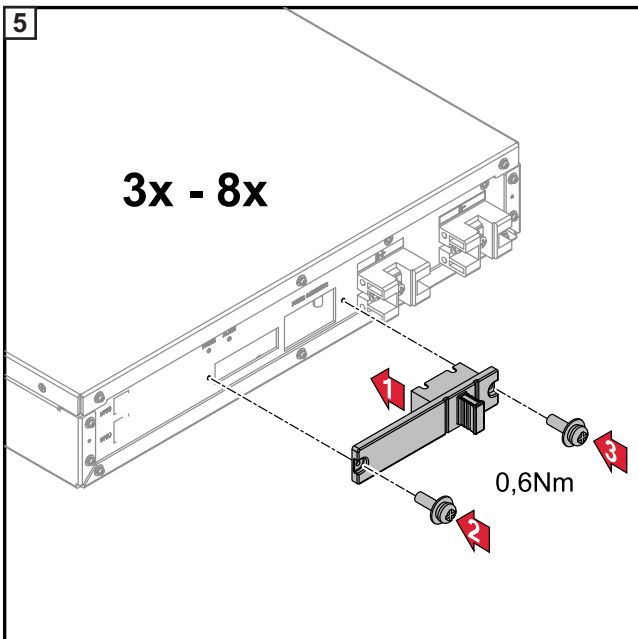
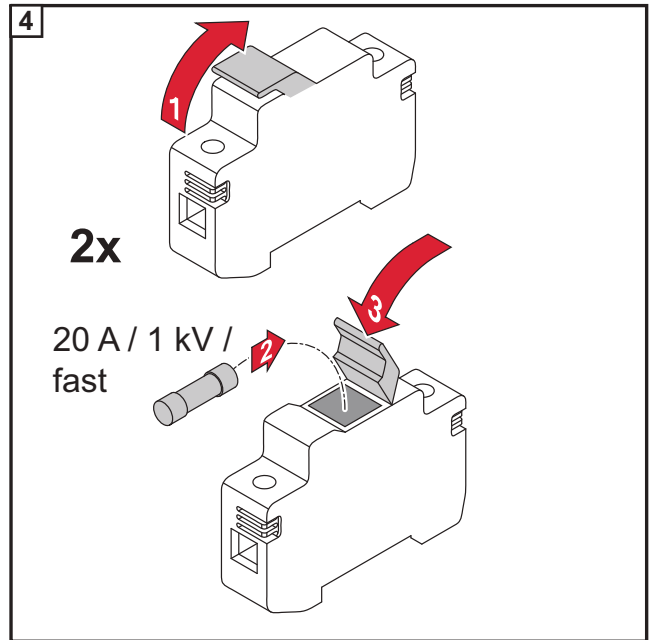
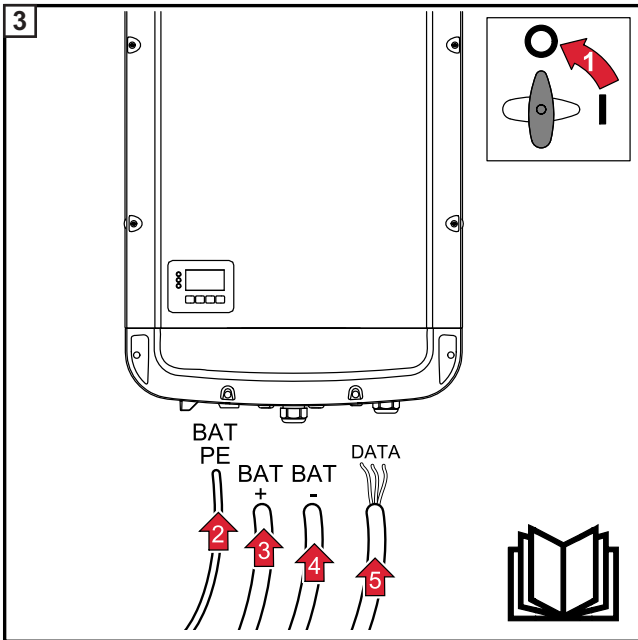
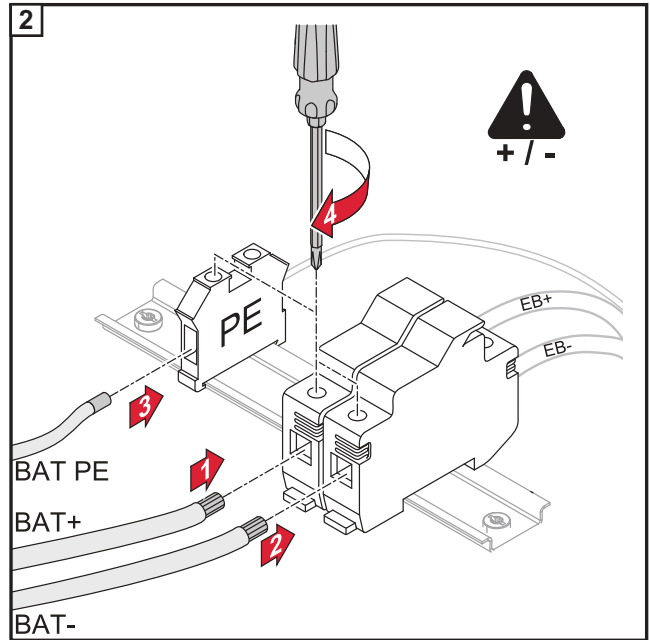
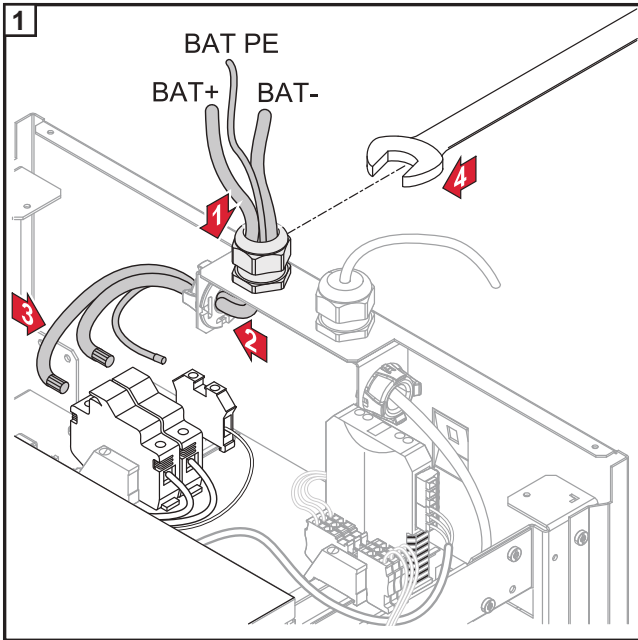

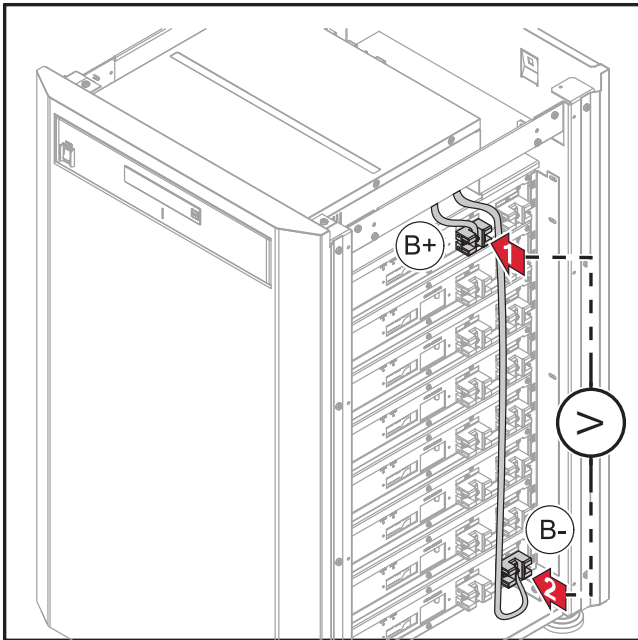

1 Check voltage B+ - B-

Solar batteries	U_{min}	U_{max}
3	100 V	175 V
4	130 V	230 V
5	160 V	290 V
6	200 V	345 V
7	230 V	400 V
8	260 V	460 V

2 Check Grounding Connection

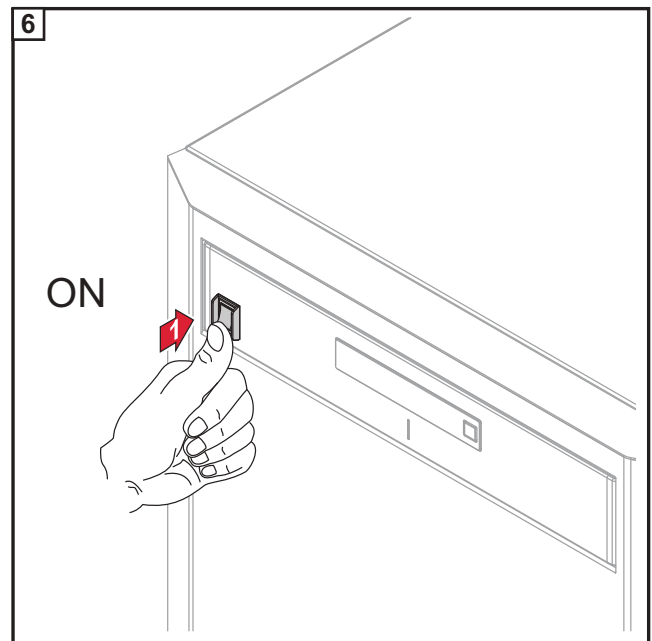
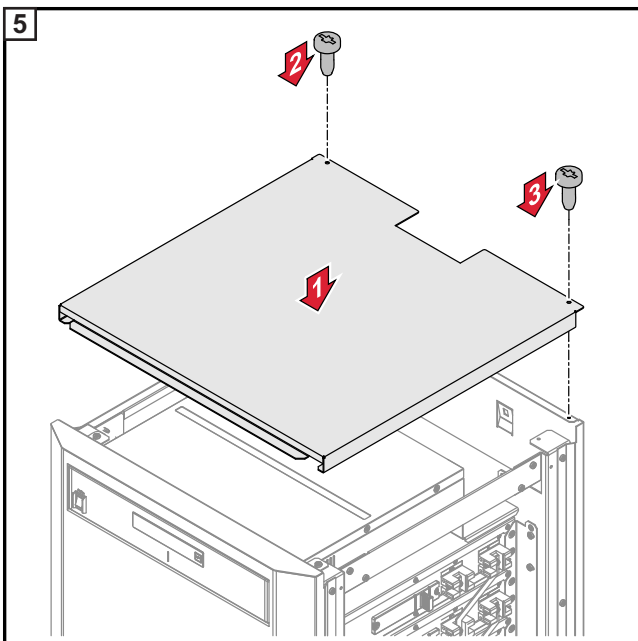
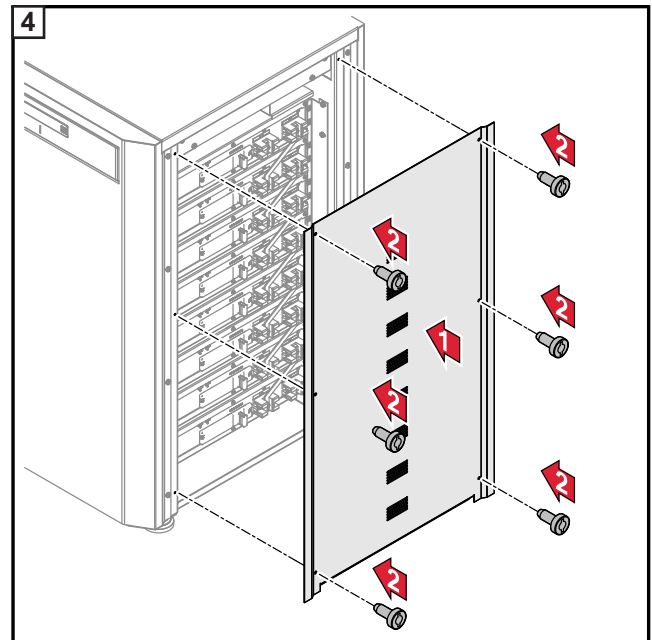
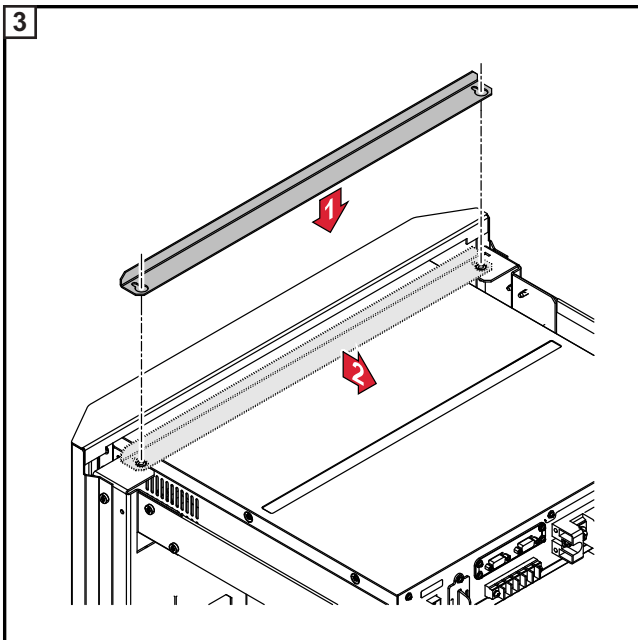

START „WiFi Access Point.“



OPTION A:

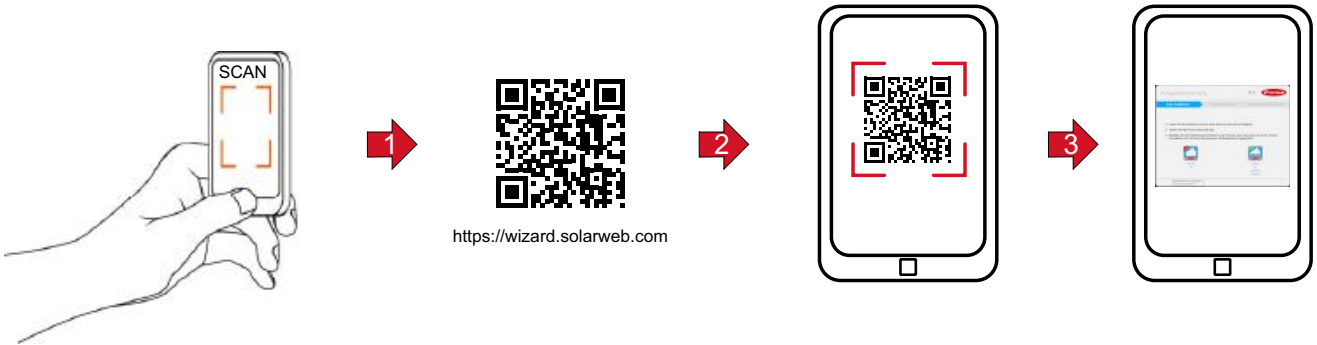

OPTION B:

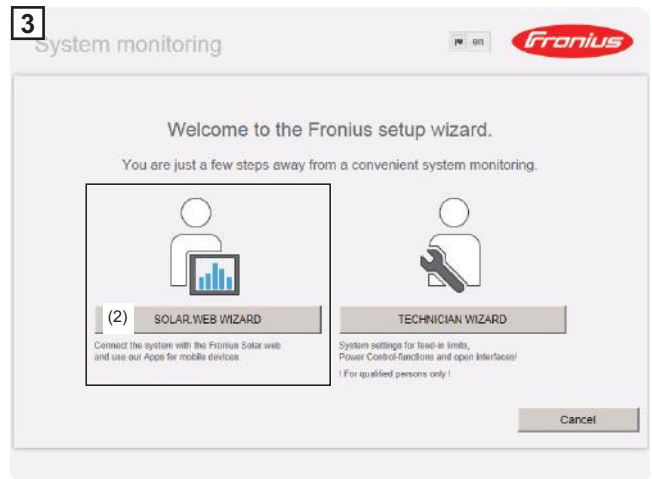
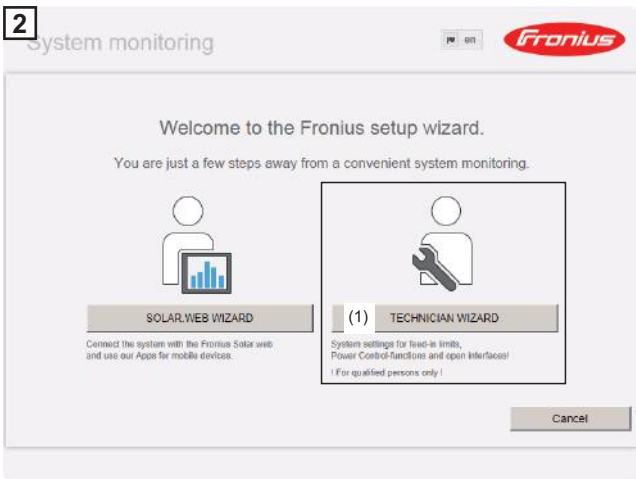
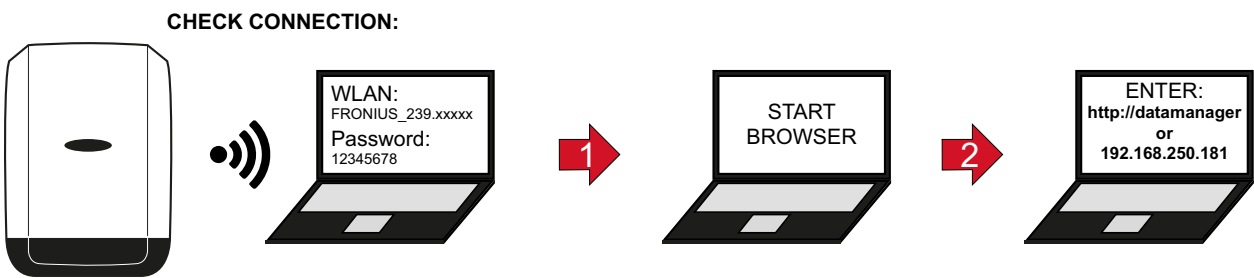

Fronius Worldwide - www.fronius.com/addresses

Fronius International GmbH
4600 Wels, Froniusplatz 1, Austria
E-Mail: pv-sales@fronius.com
<http://www.fronius.com>

Fronius USA LLC Solar Electronics Division
6797 Fronius Drive, Portage, IN 46368
E-Mail: pv-us@fronius.com
<http://www.fronius-usa.com>

Under <http://www.fronius.com/addresses> you will find all addresses of our sales branches and partner firms!